

## **Modeling of Gas Turbine Co-Propulsion Engine to Ecotourism Vessel for Improvement of the Sailing Speed**

### **O. Sulaima**

*Department of Maritime Technology,  
Faculty of Maritime Studies and Marine Science,  
University Malaysia Terengganu, Terengganu, Malaysia*

o.sulaiman@umt.edu.my

### **H. Saharuddin**

*Department of Maritime Technology,  
Faculty of Maritime Studies and Marine Science,  
University Malaysia Terengganu, Terengganu, Malaysia*

### **A.S.A.kader**

*Department of Mechanical Engineering,  
University Technology Malaysia,  
Skudai, Johor. Malaysia*

abdsaman@fkm.edu.my

### **M.Zamani**

*Department of Mechanical Engineering,  
University Technology Malaysia,  
Skudai, Johor. Malaysia*

---

### **Abstract**

Sailing speed is important an factor in choosing marine engines. The uses of gas turbine as co-propulsion engine for improving sailing speed of ecotourism vessels to fulfill requirement of SAR operation. Gas turbine co-propulsion engine have an advantage of high power to weight ratio in comparative to other heat engines. This paper presents the results and study on diesel engine, simple cycle gas turbine and regenerative gas turbine performances The relation between the thermal efficiency of heat engine to fuel consumption is used to estimate fuel consumption rate. The design of heat engine can be determined the specific heat ratio and pressure ratio of the operation cycle which will give necessary impacts to the thermal efficiency of the heat engine. Results from the numerical calculation for the implementation of gas turbine will provide he decision support. The paper also discusses the impact of co-propulsion engine to the ships stability and proper power rating of gas turbine co-propulsion engine estimated by numerical calculation in order to achieve maximum sailing speed up to 35 knots.

**Keywords:** Gas Turbine, Regeneration, Sailing Speed Thermal Efficiency, Fuel Consumption

---

## **1. INTRODUCTION**

The sailing speed of ecotourism can be improved by several methods. In this research implementation of gas is proposed as co-propulsion engine to improve the ecotourism vessel sailing speed up to 35knots. The vessel under study is the important transport connecting the mainland from Mersing jetty to Tioman Island. High speed sailing is necessary for the vessel to

carry out the search and rescue operation in open sea under emergency circumstances. Besides, improving passenger ferry sailing speed will overcome the problem of vessels shiftment delays during peak season in May.

Gas turbine also called a combustion turbine is a rotary engine that extracts energy from a flow of combustion gas. In order to adapt the function, the gas turbine composes of four important components, which are compressor, combustion chamber, turbines and exhaust. Energy is added to gas stream by combustor through ignition of the mixture of atomized fuel and air. The gaseous streams are then directed through a nozzle toward a turbine. The hot gases stream will spin the turbine and empower the compressor.

Comparative to others heat engine, gas turbine will have the advantages of high power to weight ratio. The gas turbine provides the same output power as the diesel engine having more compact design and smaller in sizes and weight in comparison with diesel engine. However, under certain circumstances, the diesel engine will show higher in fuel efficiency in comparative to gas turbine [1, 2].

The design of gas turbine will give impacts to the performances of gas turbine. Design must take into account on specific heat ratio and the pressure ratio in order to produce high performance gas turbine co-propulsion engine. These two variables give significant change of thermal efficiency of gas turbine co-propulsion engine.

## 2. MODELLING PROCESS

The thermodynamic properties of the each heat engine were emphasized three types of heat engine were selected and put into study. Diesel cycle, Bryton cycle and combine cycle are studies to examine the properties of individual heat engine.

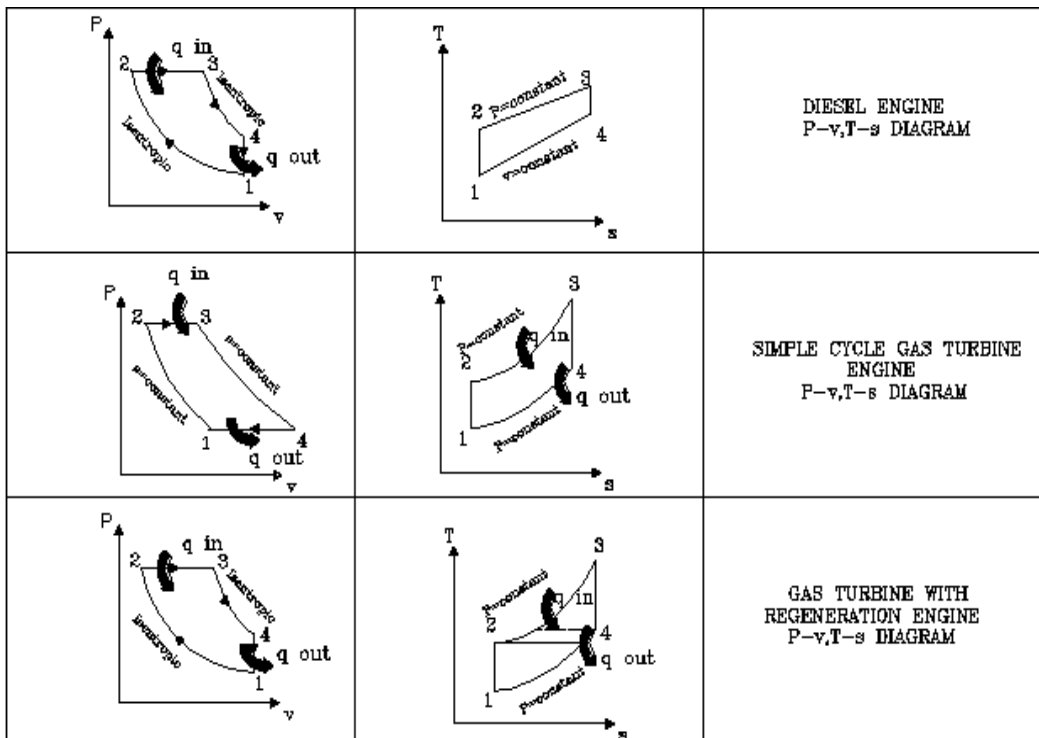

FIGURE 1: thermodynamic properties of co-propulsion engine

A survey is done by a visiting the passenger Fast Ferry Company located at Mersing jetty, Johor. Data collections are done on the vessel understudy. These included ship's particular general arrangement, propulsion engine specification, sailing speeds and fuel consumption rate [3,4].

The thermodynamic properties of the following heat engine were presented in curve to examine the properties of each heat engine. The plotting tools; Matlab is applied for plotting purposes. The thermodynamic formula needs to translate to the M-code in order to present a relation curve [5,6]. Table 1-4 show the M-code for propulsion engines.

**TABLE1:** Thermal efficiency of co-propulsion engine

Types of co-propulsion engine	Thermal efficiency formula
Diesel engine	$n_{ch,diesel} = 1 - \frac{1}{r^{k-1}} \left[ \frac{r_c^k - 1}{k(r_c - 1)} \right]$
Simple cycle Gas turbine	$n_{ch,bryton} = 1 - \frac{1}{r_p^{(k-1)/k}}$
Regeneration gas turbine	$n_{ch,regen} = 1 - \left( \frac{T_1}{T_3} \right) (r_p)^{k(k-1)}$

**TABLE 2:** M-code for Diesel engine

```
%M
code for thermodynamic properties of diesel engine
k=1.4;
rco=2;
1);
1);
1);
nD=1
e;
legend('at k=1.4');
ratio,r);
title('thermal efficiency vs comprssion ratio');
r=[2:2:24];
a=r.^k
b=(rco^k)
c=k*(rco)
e=b./(a*c);
plot(r,nD,'red');
xlabel('compress
ylabel('Dieselefficiency,nD');
```

**TABLE 3:** M-code for simple cycle gas turbine

```
%M-code for thermodynamic properties of simple gas turbine
k=1.4;
x=(k-1)/k;
rp.^-xplot(rp,nB,'magenta');
ylabel('Thermal efficiency,nB');
k=1.4);
efficiency of gas turbine vs pressure ratio');
rp=[1:2:24];
nB=1-
xlabel('pressure ratio,rp');
legend('at
title('Thermal
```

**TABLE 4:** M-code for regeneration gas turbin

```
%M-code for thermodynamic properties of regeneration gas turbine
k=1.4;
r=[1:2:50];
t=0.5;
x=(k-1)/k;
nR=1-t*(r.^x);
plot(r,nR,'black');
xlabel('pressure ratio,r');
ylabel('Thermal efficiency,n');
legend('regen turbine at k=1.4');
title('regen gas turbine thermal efficiency');
```

The fuel consumption rate of each heat engine will then translate from the thermal efficiency using formula state below:

$$\text{Fuel consumption} = \frac{\left(\frac{3412 \text{ Btu}}{\text{Wh}}\right)}{\text{thermal efficiency of diesel}}$$

After determining the types of co-propulsion engine to implement, the power output selection can be performed by numerical calculation by using the related formula follow the sequence as shown in Figure 2.

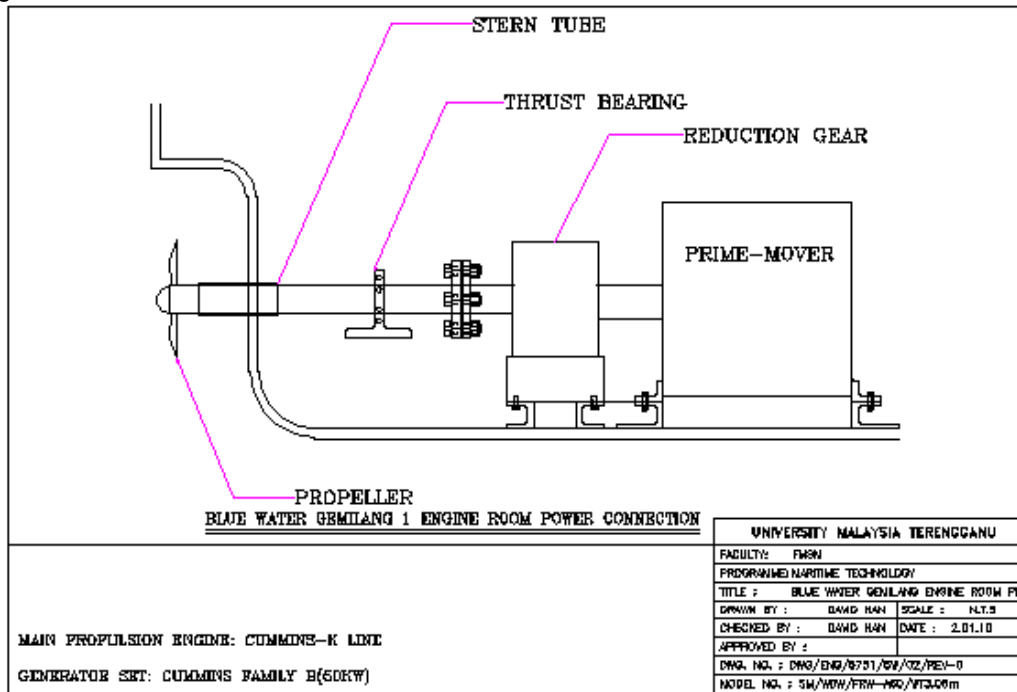

FIGURE 2: Arrangement of machinery onboard ship

TABLE5: Formula for numerical power calculation

Types of power	Simplified	Formula
Effective horse power (EHP)	EHP=RV	Effective horse power required to tow a hull without a propeller.
Thrust horsepower (THP)	$THP = T \times V_a$	thrust horsepower is power delivered by propeller to the water
Delivered Horsepower	$DHP = \frac{THP}{\eta_p}$	Delivered horsepower (DHP) is the power that is delivered by the shaft to the propeller.

Shaft horsepower

$$SHP = \frac{DHP}{n_B n_S} = \frac{DHP}{n_M}$$

Shaft horse power is the power delivered by engine to the shaft after gearing and thrust bearing.

Brake horse power

$$BHP = \frac{SHP}{n_G}$$

The power delivered by the prime mover at its connection flange is called brake horsepower.

### 3. RESULT AND DISCUSSION

The data acquired during the survey are presented in tablelar form. The table 6 below shows the detail of the passenger ferry company. Bluewater Express ferry services are a company established in 1999. The core business offered are the ferry services to the passengers coming to Pulau Tioman. The company currently owned 8 fast ferries for the passenger services. Besides, the company owned a few cargo ships modified from the ordinary fisherman boat to transfer cargoes in between Pulau Tioman to the mainland to full fill the demands in the Tioman Island. (Refer to Table 6, and Table 7).

**TABLE 6:** Details of the ferry company

1	Company name:	BlueWater Express
2	Location:	Mersing,Johor
3	Name of Company's owner:	En.Rizam Bin Ali
4	Types of business:	passenger fast ferry
5	Routine:	Mersing jetty to Tioman
6	Distance:	35n miles
7	Name of Vessel:	Gemilang 1
8	Types of vessel:	Fiber single hull vessel
9	Vessel Manufacturer:	PT.Bintan Shipping Bioteknik Tanjung Pinang Shipyard
10	Maximum number passenger:	100 passengers

**TABLE 7:** Ship Hull details

1	Length overall	23.7m
2	beam	5.20m
3	draft	2.20m
4	Hull types:	Single hull
5	Materials	Fiber class
6	Detail of lighting system	12fluerecent light(45watt),12 others light bulb(24watt)
7	Number of pump required	6 batt pump,1 electrical pump,2 mechanical pump(ramp pump)
8	Vessel average sailing speed	20knots
9	DWT(base on dimension)	271.2tonnes

The vessel under studies named Gemilang 1. The vessel was constructed by PT. Bintan Shipping Bioteknik in Tanjung Pinang, Indonesia. The ship hull has the dimension as shown in the Table. The machinery used onboard was drafted for the reason of recommendation on the implementation of co-propulsion engine ( See Figure 3 and 4 ).

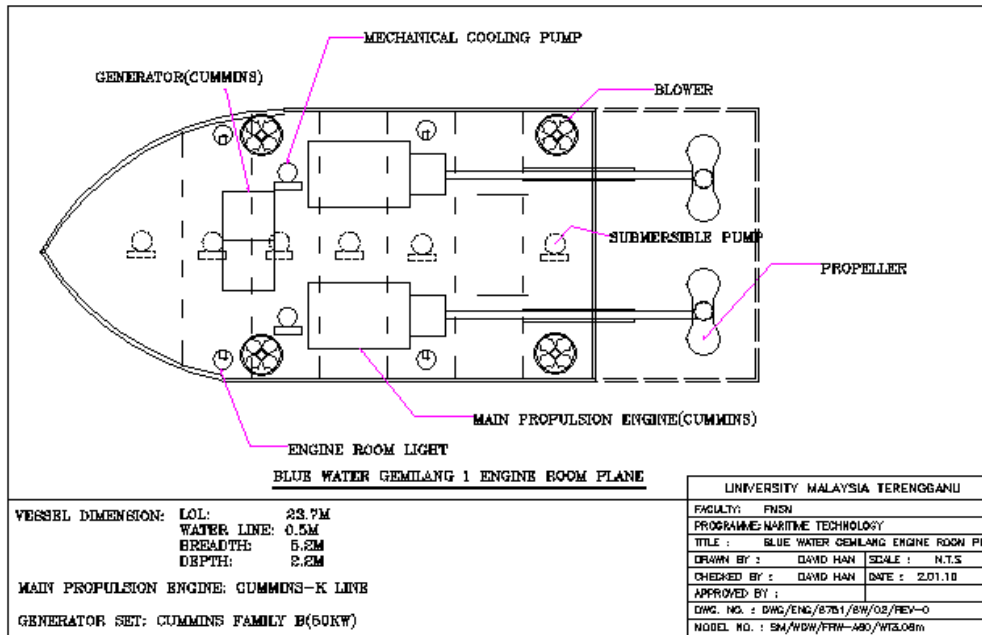

FIGURE 3: Machinery arrangement in Gemilang 1 engine room

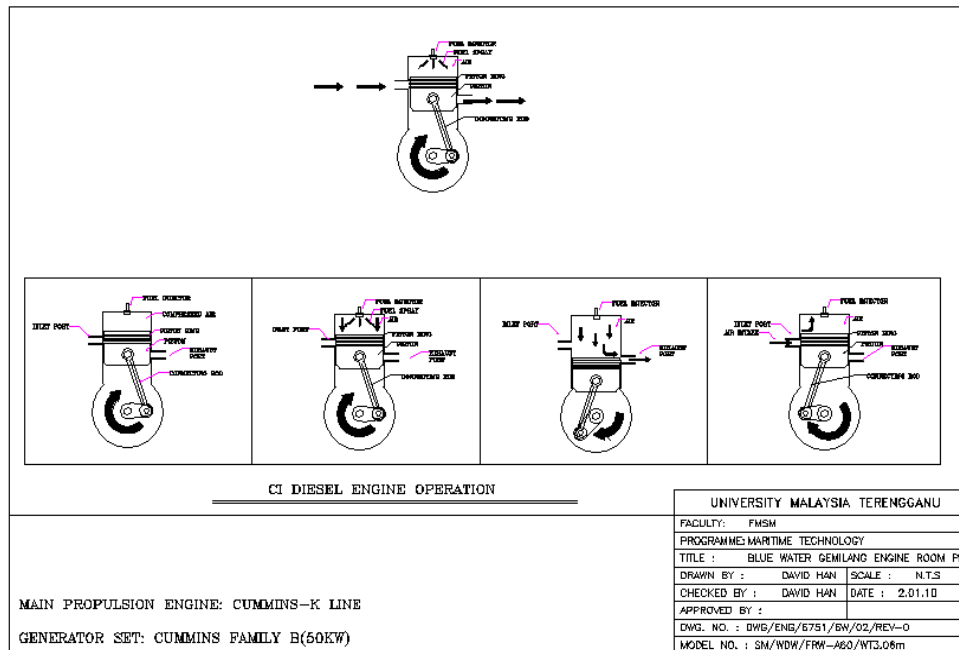

FIGURE 4: Mechanism of CI diesel propulsion engine in Gemilang 1

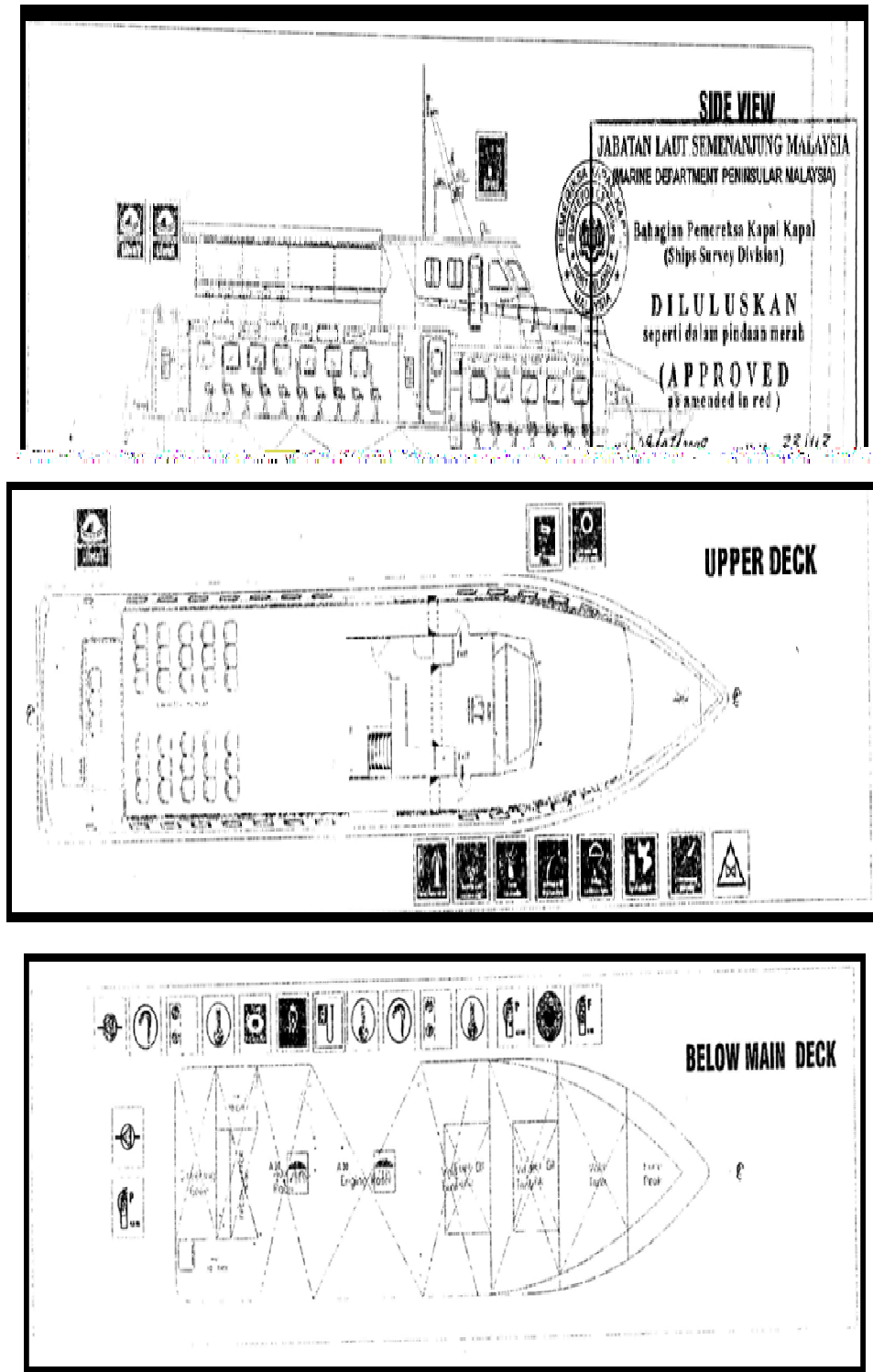

FIGURE 5: GA-plan of Gemilang 1 (general arrangement plan)

Gemilang1 is equipped with 2 propulsion engines and capable to propel the ship at sailing speed up to 20 knots. In order to fulfill the demand of the machinery that is necessary for sailing the desired sailing speed, redundant systems such as water pump system, lighting system, and the

electronics devices for the navigational purposes are installed. The vessel is also equipped with a generator power rating up to 50kW. The properties of the propulsion engine are presented in the Table 8 below.

**TABLE 8:** Propulsion engine specification

ENGINE DETAILS:		DESCRIPTION:
1	Engine model:	KTA-M4 Marine propulsion engine
2	Engine types:	IN-LINE, 6 CYLINDER, 4 STROKE DIESEL
3	Bore & stroke:	159 mm x 159 mm (6.25 in x 6.25 in)
4	Displacement:	19 L (1150 cc)
5	Rotational direction:	COUNTERCLOCKWISE FACING FLYWHEEL
6	Aspiration:	TURBOCHARGED AFTERCOOLED
7	Fuel consumption:	135.1 (35.7)Rated: 94.6 (25.0)ISO
8	Number of engine used:	2pcs
9	Rating definition:	HEAVY DUTY
10	Emission :	IMO STANDARD
11	Engine rotation(RPM) :	2100revolution per second
12	Power rating:	522kW

In predicting the efficiency of gas turbine and diesel engine, assumption has been made in order to standardize the condition at where the cycles performed. In comparing the performance of gas turbine versus diesel engine; we need to make some assumption on the working fluid for both of the system. The air is necessary in carrying out the combustion process. Fresh air entering the combustion chamber was considered under the cold air standard assumptions[10, 11]. Where by the specific heat ratio  $k$ , is represented by  $k=1.4$  (specific heat ratio value under room temperature) (See Figure 6).

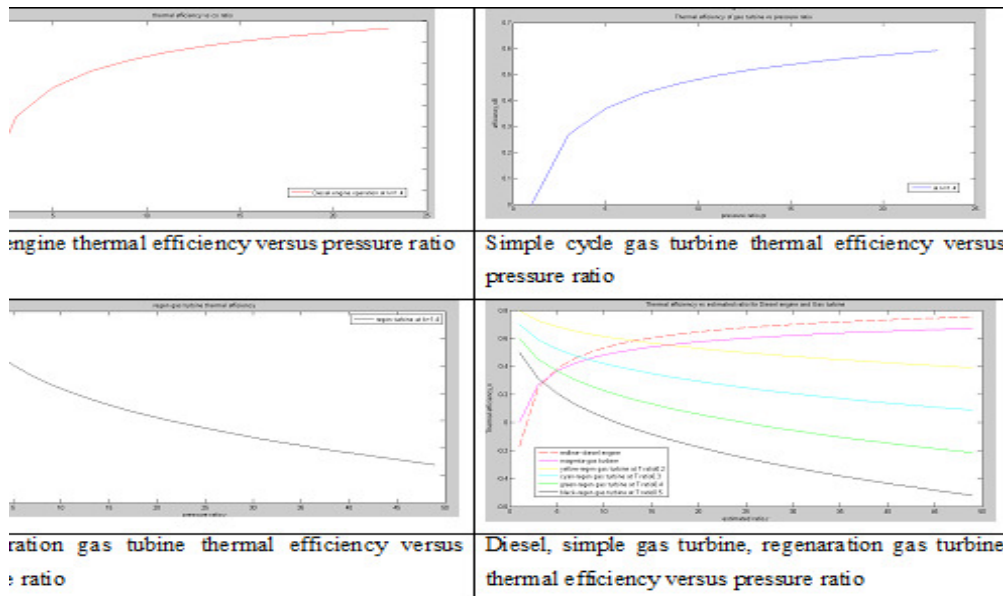

**FIGURE 6:** Thermal efficiency of each types co-propulsion engine

Besides, assumption is made on that the pressure ratio and cutoff ratio are similar in term of working condition. Compression ratio  $r$ , is defined as the ratio of the volume of its combustion chamber; from its largest capacity to its smallest capacity. It is a fundamental specification for many common combustion engines. While the pressure ratio  $\pi$ , for gas turbine is defined as ratio of the pressure at the core engine exhaust and fan discharge pressure compared to the intake pressure to the gas turbine engine.



$$r_p = \frac{p_2}{p_1} = \frac{v_2}{v_1} = r$$

$$r_p = r_c = r_A$$

Where:

$r_A$  = *Estimated ratio on working condition*

The study involved the feasibility of implementing a gas turbine to improve the vessel sailing speed up to 35 knots. The study relates the operation of the gas turbine and diesel engine with thermal efficiency of the cycle.

Figure 7 illustrates the relation between thermal efficiency with pressure ratio for simple cycle of gas turbine and diesel engine. It shows that at the early state of the curve, gas turbine show steeper increment in thermal efficiency with the increasing pressure ratio.

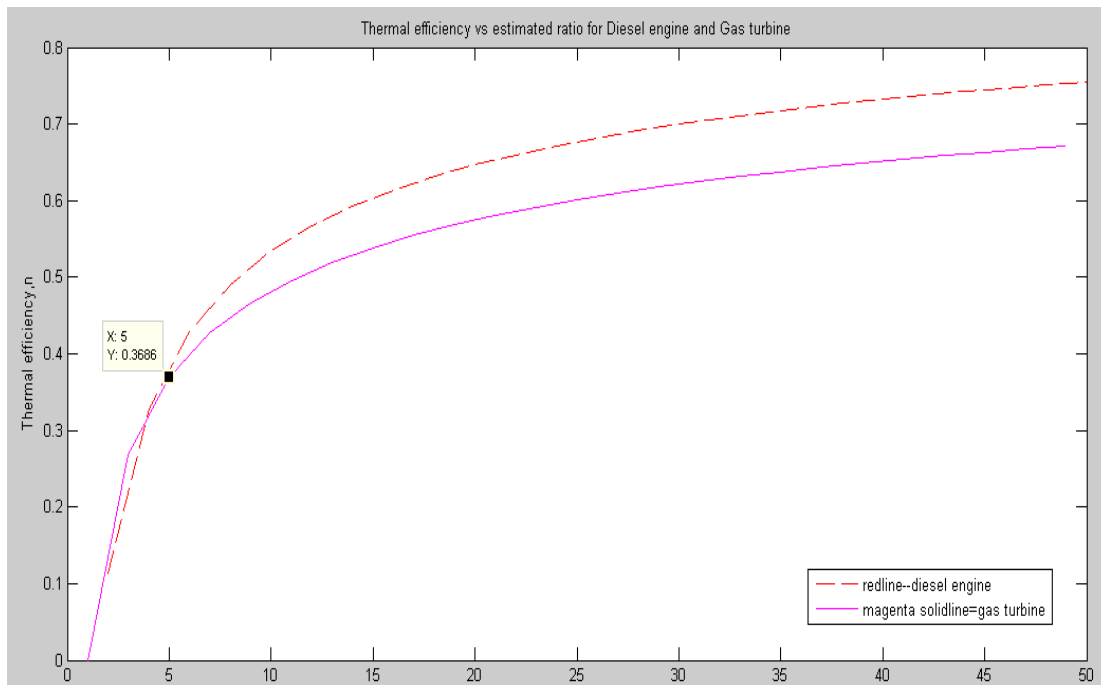

**FIGURE 7:** Thermal efficiency of each types co-propulsion engine

The performance of gas turbine and diesel engine overlaps at pressure ratio 5. In the middle state of the curve, the diesel engine has higher thermal efficiency with the increasing pressure ratio. From the curve shown, it is observed that the simple cycle gas turbine engine is less efficient in comparison to diesel engine.

The gas turbine operation can be improved by applying the regeneration cycle. The temperature of exhaust gas leaving the turbine is higher than the temperature of the air leaving the compressor. By leading the heat exhaust gaseous through the heat recuperates to preheat the compressed air from the compressor can improve the thermal efficiency of the gas turbine. Figure 8 shows the thermal efficiency curve between diesel engine, simple cycle gas turbine and the regenerative gas turbine at variable temperature ratio [6, 7].

Figure 8 illustrates the regenerative gas turbine with the minimum temperature ratio between the exhaust gas and the compressed air shows higher thermal efficiency in the early stage, the thermal efficiency of the following gas turbine decrease gradually with the increasing of the pressure ratio. From the diagram it is that the gas turbine with regeneraton is the ideal selection for the co-propulsion engine because it shows high thermal efficiency in low pressure ratio. Low

pressure ratio carries significant information of low back work ratio and horse power of the following engine [8, 9].

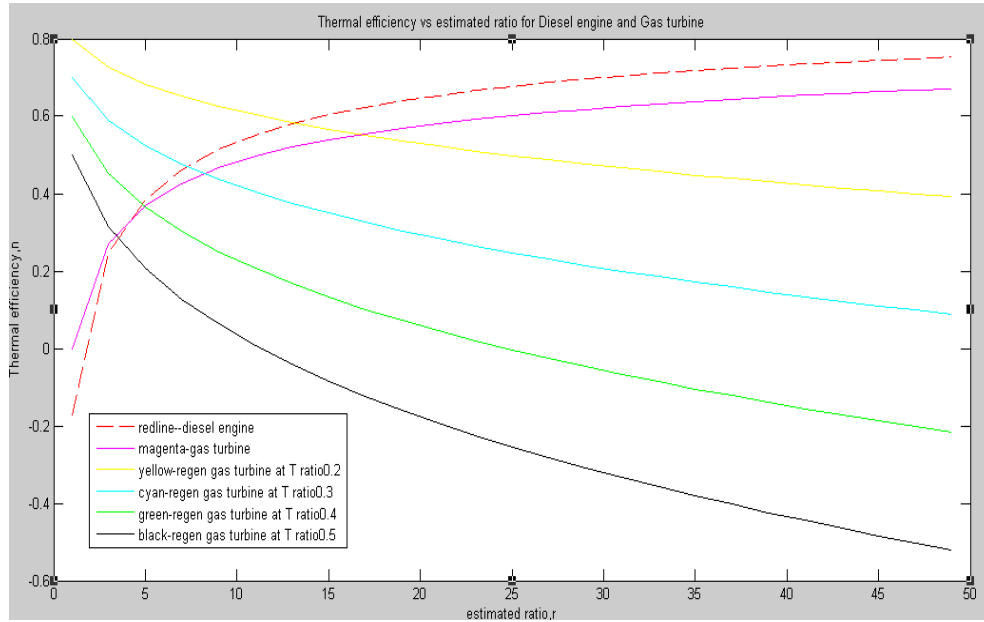

**FIGURE 8:** Thermal efficiency of each types co-propulsion engine

### Fuel consumption of co-propulsion engine

The fuel consumption always the criteria to consider during the marine engine selection, the optimum usage of fuel will ensure profits to the passenger company. By using the formula as stated below, the thermal efficiency of co-propulsion engine can be interrelated.

$$\text{Fuel consumption} = \frac{\left( \frac{3415 \text{ Btu}}{n_{th}} \right)}{\text{net heating value of diesel}}$$

In this case, we select the diesel fuel as the source for the heat engine. The diesel fuel having the net heating value of 130000btu/gallon. Substitute the net heating value, then the fuel consumption rate can be represented by the curve plotted by MATLAB as shown in Figure 9.

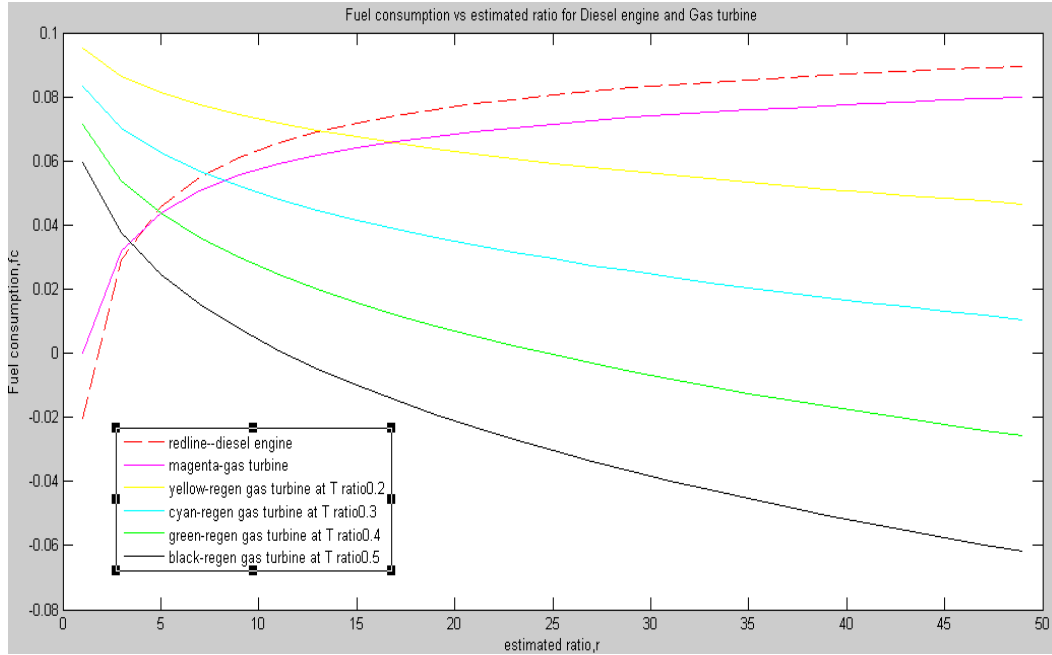

FIGURE 9: Fuel consumption (gallon) of each types co-propulsion engine

From the curve shown in Figure 9 it can be concluded that the fuel consumption rate versus estimated ratio for the diesel engine, simple cycle gas turbine, and regenerative gas turbine shows the similar trend. The regeneration gas turbine with the temperature ratio 0.3 showing a moderate fuel spent over the power production. Hence, the regenerative gas turbine will be the ideal selection as co-propulsion engine among the others. Location for the regeneration gas turbine in engine room [8, 10].

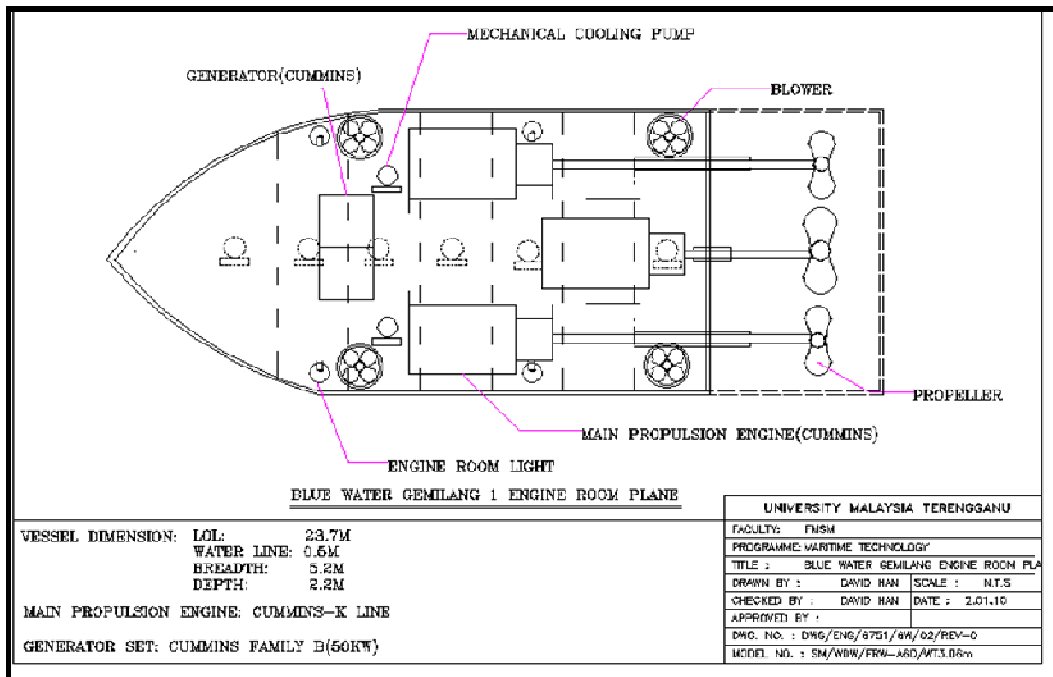
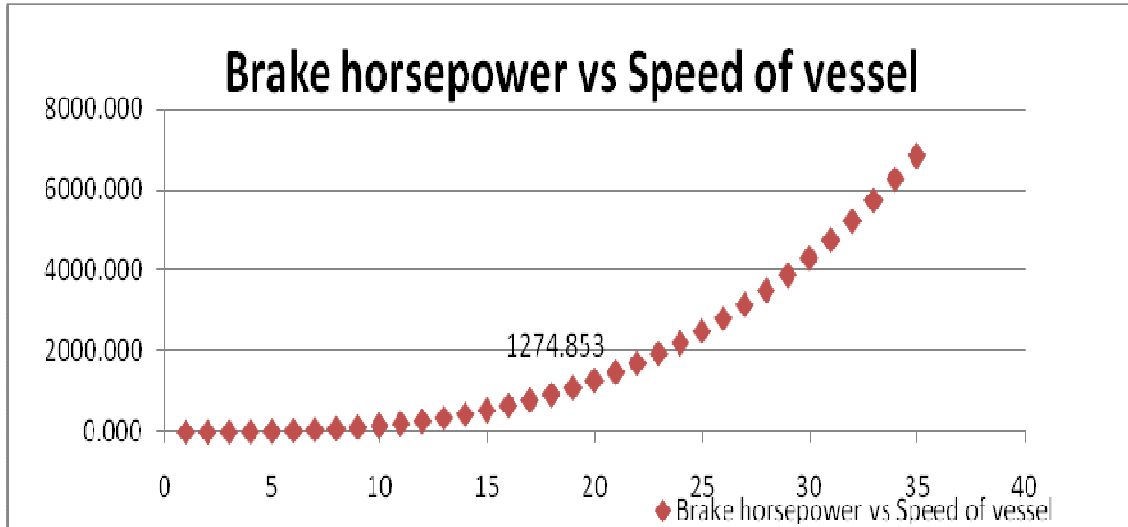

FIGURE 10: Recommendation for distribute the co-propulsion engine

**3.2 Power calculation**

The current existing diesel engines remain as a main propulsion engine to sail the ship at economic speed. The minimum power required to propel the vessel is computed theoretically. The numerical modeling involve assumption on the numbers of crews, weight of luggage and cargoes carried to estimate the dead weight tones of the vessel under studies. The brake horse power obtained base on theoretical calculation at variable speed is shown in the Table 9.



**FIGURE 11:** Brake horse power at various speeds

**TABLE 9:** Validation on the power calculation

Description	Theoretical calculation	Engine applied onboard ship
Value (HP)	1274.85hp	1400hp
Value (kW)	950.66kW	1043.98kW

From the diagram the power rating of the diesel engine calculated based on theoretical calculation are closed to the diesel engines currently applied on that following vessel. From the survey, we knew that there were 2 diesel engines with power rating of 700hp each applied on the vessel to propel the vessel to sail at optimum speed. On economy aspect, the selection of higher horsepower propulsion engines is necessary for the vessel to sail at optimum speed instead of sailing a vessel with full speed at engine maximum performances. The speed control can be done by adjusting on the throttling valve located at fuel pump attached to diesel engine. Besides, in real environment, there are some other factors to take into consideration. Air resistant due to the size of the superstructure of the vessel may require higher power propulsion to propelling the vessel to move forward [11,12].

For the co-propulsion engine, the output power becomes the terminology chosen in select the marine engine. Referring to the curve shown, the resistances of the vessel differ at variable speed. Hence, numerical calculation on the power at various speeds is necessary in order to ensure the vessel can sail at desired speed (See Figure 12).

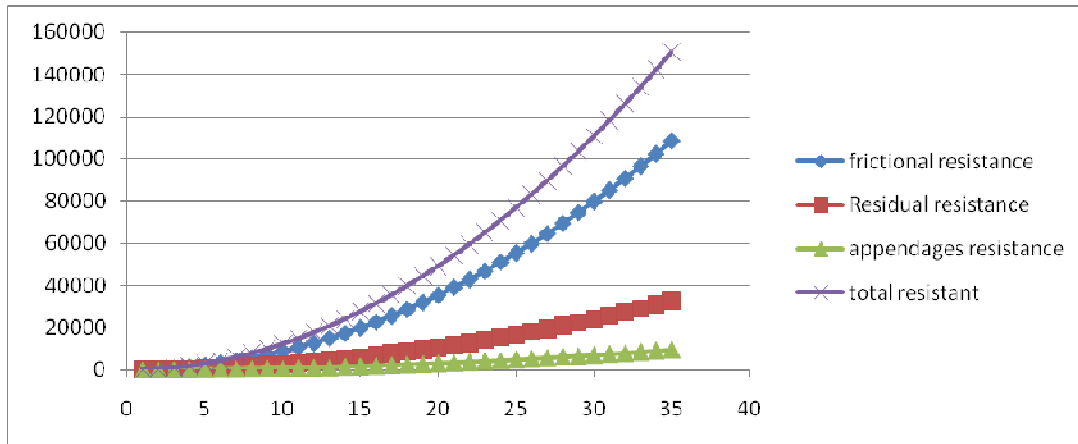

FIGURE 12: Types of resistances at variable speed

Figure13 shows the types of power at various speed. The minimum power required to propel a vessel to move forward is the effective horse power. The brake horsepower is the highest power and will encounter power loss in each transition state from the engine to the shaft following with the propeller.

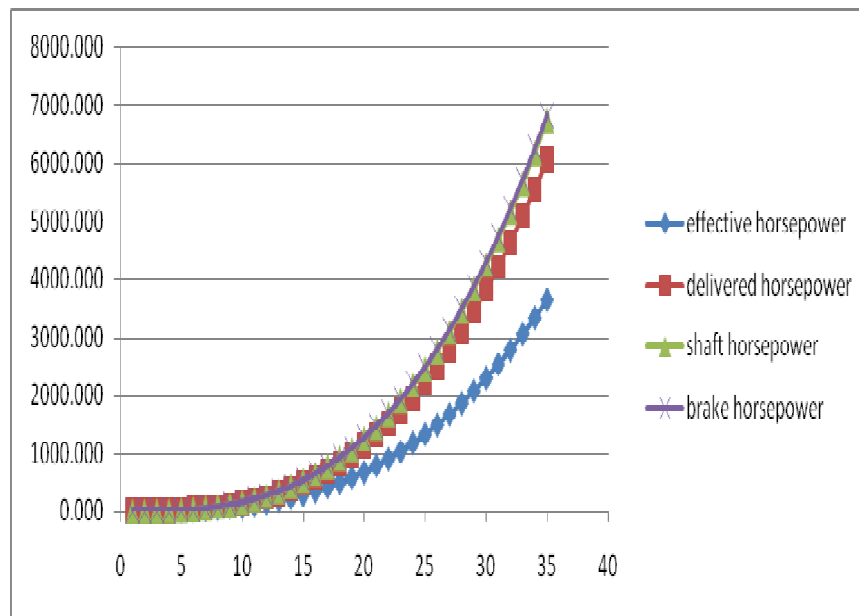

FIGURE 13: Types of power at variable speed

The result from the numerical calculation on the power output of co-propulsion engine shown that the minimum brake horsepower required for the co-propulsion engine is 1274.85hp. The recommended horse power for co-propulsion to implement is 1300hp. That is 10% margin of power excess to suit the speed of vessel. The regeneration gas turbine is selected after performing the analysis by plotting curve. The exhaust gas released by regeneration gas turbine was retracted and used to reheat the compressed gas existing from the compressor.

The paper aimed to improve ecotourism vessel sailing speed by implement a gas turbine as co-propulsion engine. The objective of the to improve the speed of vessel up to 35 knots with minimum fuel consumption is demonstrated in the power curve. Numerical calculation on the power output of co-propulsion engine shown that the minimum brake horsepower required for the co-propulsion engine is 6263.35hp [13,14]. The recommended horse power for co-propulsion to

implement is ranging from 6890hp up to 6900 hp. That is 10% margin of power excess to suit the speed of vessel. The result of regenerative gas turbine have an advantages by reduces the heat release to the environment. In economy aspect, although gas turbine co-propulsion engine display higher initial cost, but the lower operating and maintenances cost will reduced the payback period of the following investment.

#### 4.0 CONCLUSION

The paper proposed to improve ecotourism vessel sailing speed by implementing a gas turbine as co-propulsion engine. The study of feasibility of implementing a gas turbine as co-propulsion engine relates the performances of the gas turbine to the thermal efficiency and fuel consumption. The objective of this research is to improve the speed of vessel up to 35 knots with minimum fuel consumption. From the result of this study, the gas turbine is a practical system recommended to install into ecotourism vessel. The recommended gas turbine to be installed lay in the power output ranging 6890hp to 6900 hp.

Acknowledgement: The author thanks Mr. Ong See Ha for his direct contribution to this research

#### 4. REFERENCES

1. Boyce, M.P., (2001) "Cogeneration and combined Cycle Power Plant", Chapter 1, ASME Press, NY
2. Boyce M.P Meherwan., P.Boyce, Phd, Pe. "Cogeneration and Combined Cycle Power Plant", Chapter 1, Gas turbine (third edition)
3. Yousef S.Najjar., "Enchancement of performances of gas turbine engines by inlet air
4. Farmer.R., "Design 60% Net Efficiency in Frame 7/9H Steam Cooled CCGT" Gas turbine World,May-June 1995
5. Gas turbine (third edition) Engineering Handbook, Meherwan P.Boyce, Phd. And Pe
6. Roy L. Harrigton. , "Marine Engineering", Engineering Technical Department, New port News shipbuilding and Dry Dock Company
7. Roberto Carapellucci. , Adriano Milazzo, "Thermodynamic optimiation of the reheat chemically recuperated gas turbine" Department of Engineering University of L'Aquila, Italy
8. Yunus A cengel. , "Thermodynamic an engineering approach six edition", University of Nevada, Reno, Michael A.Boles, University of north Carolins
9. O.Sulaiamn et al. "Potential of Biomass cogereation for Marne System Powering, Bioscience, Biotechnology Journal, Vol (7) 2, 2010
10. Blake,J.W and R.W.Tumy., (1950), " Huey Gas Turbine Ticks Off 3400 Hours."Powe, Vol. 94, February, pp96-102
11. C.B Barras (2004)., " Ship Design and Performance for Master and Mates ." Elsevier's Science and Technology. Oxford: 55-81
12. Parks WP., Jr,Hoffman P., Karnitz MA., Wright IG. "The advance gas turbine systems program in the USA."
13. J,Schubert F,Ennis PJ,editor.Materials for advanced power engineering, Forschungszentrum Julich; pp 1789-1805

14. I.G.wright and T.B.Gribbons.,(2006) "Recent Development in Gas Turbine and Technology and Their implication forSyngas Firing" Material Sciences and Technology Division, Oak Ridge National Laboratory, USA; 3612-3619
15. William D. Callister., Material Science and Engineering: an Introduction. Department of Metallurgical Engineering,The University of Utah: 743, 838-860