

Methodology of Mathematical Error-Based Tuning Sliding Mode Controller

Farzin Piltan

Industrial Electrical and Electronic Engineering SanatkadeheSabze Pasargad. CO (S.S.P. Co), NO:16 ,PO.Code 71347-66773, Fourth floor Dena Apr , Seven Tir Ave , Shiraz , Iran

SSP.ROBOTIC@yahoo.com

Bamdad Boroomand

Industrial Electrical and Electronic Engineering SanatkadeheSabze Pasargad. CO (S.S.P. Co), NO:16 ,PO.Code 71347-66773, Fourth floor Dena Apr , Seven Tir Ave , Shiraz , Iran

SSP.ROBOTIC@yahoo.com

Arman Jahed

Industrial Electrical and Electronic Engineering SanatkadeheSabze Pasargad. CO (S.S.P. Co), NO:16 ,PO.Code 71347-66773, Fourth floor Dena Apr , Seven Tir Ave , Shiraz , Iran

SSP.ROBOTIC@yahoo.com

Hossein Rezaie

Industrial Electrical and Electronic Engineering SanatkadeheSabze Pasargad. CO (S.S.P. Co), NO:16 ,PO.Code 71347-66773, Fourth floor Dena Apr , Seven Tir Ave , Shiraz , Iran

SSP.ROBOTIC@yahoo.com

Abstract

Design a nonlinear controller for second order nonlinear uncertain dynamical systems is one of the most important challenging works. This paper focuses on the design of a chattering free mathematical error-based tuning sliding mode controller (MTSMC) for highly nonlinear dynamic robot manipulator, in presence of uncertainties. In order to provide high performance nonlinear methodology, sliding mode controller is selected. Pure sliding mode controller can be used to control of partly known nonlinear dynamic parameters of robot manipulator. Conversely, pure sliding mode controller is used in many applications; it has an important drawback namely; chattering phenomenon which it can causes some problems such as saturation and heat the mechanical parts of robot manipulators or drivers.

In order to reduce the chattering this research is used the switching function in presence of mathematical error-based method instead of switching function method in pure sliding mode controller. The results demonstrate that the sliding mode controller with switching function is a model-based controllers which works well in certain and partly uncertain system. Pure sliding mode controller has difficulty in handling unstructured model uncertainties. To solve this problem applied mathematical model-free tuning method to sliding mode controller for adjusting the sliding surface gain (λ). Since the sliding surface gain (λ) is adjusted by mathematical model free-based tuning method, it is nonlinear and continuous. In this research new λ is obtained by the previous λ multiple sliding surface slopes updating factor (α). Chattering free mathematical error-based tuning sliding mode controller is stable controller which eliminates the chattering phenomenon without to use the boundary layer saturation function. Lyapunov stability is proved in mathematical error-based tuning sliding mode controller with switching (sign) function. This

controller has acceptable performance in presence of uncertainty (e.g., overshoot=0%, rise time=0.8 second, steady state error = $1e-9$ and RMS error= $1.8e-12$).

Keywords: Nonlinear Controller, Chattering Free Mathematical Error-based Tuning Sliding Mode Controller, Uncertainties, Chattering Phenomenon, Robot Arm, Sliding Mode Controller, Adaptive Methodology.

1. INTRODUCTION

The international organization defines the robot as “an automatically controlled, reprogrammable, multipurpose manipulator with three or more axes.” The institute of robotic in The United States Of America defines the robot as “a reprogrammable, multifunctional manipulator design to move material, parts, tools, or specialized devices through various programmed motions for the performance of variety of tasks”[1]. Robot manipulator is a collection of links that connect to each other by joints, these joints can be revolute and prismatic that revolute joint has rotary motion around an axis and prismatic joint has linear motion around an axis. Each joint provides one or more degrees of freedom (DOF). From the mechanical point of view, robot manipulator is divided into two main groups, which called; serial robot links and parallel robot links. In serial robot manipulator, links and joints is serially connected between base and final frame (end-effector). Most of industrial robots are serial links, which in n degrees of freedom serial link robot manipulator the axis of the first three joints has a known as major axis, these axes show the position of end-effector, the axis number four to six are the minor axes that use to calculate the orientation of end-effector and the axis number seven to n use to reach the avoid the difficult conditions (e.g., surgical robot and space robot manipulator). Dynamic modeling of robot manipulators is used to describe the behavior of robot manipulator such as linear or nonlinear dynamic behavior, design of model based controller such as pure sliding mode controller and pure computed torque controller which design these controller are based on nonlinear dynamic equations, and for simulation. The dynamic modeling describes the relationship between joint motion, velocity, and accelerations to force/torque or current/voltage and also it can be used to describe the particular dynamic effects (e.g., inertia, coriolios, centrifugal, and the other parameters) to behavior of system[1-10]. The Unimation PUMA 560 serially links robot manipulator was used as a basis, because this robot manipulator is widely used in industry and academic. It has a nonlinear and uncertain dynamic parameters serial link 6 degrees of freedom (DOF) robot manipulator. A nonlinear robust controller design is major subject in this work. Controller is a device which can sense information from linear or nonlinear system (e.g., robot manipulator) to improve the systems performance [3]. The main targets in designing control systems are stability, good disturbance rejection, and small tracking error[5]. Several industrial robot manipulators are controlled by linear methodologies (e.g., Proportional-Derivative (PD) controller, Proportional- Integral (PI) controller or Proportional- Integral-Derivative (PID) controller), but when robot manipulator works with various payloads and have uncertainty in dynamic models this technique has limitations. From the control point of view, uncertainty is divided into two main groups: uncertainty in unstructured inputs (e.g., noise, disturbance) and uncertainty in structure dynamics (e.g., payload, parameter variations). In some applications robot manipulators are used in an unknown and unstructured environment, therefore strong mathematical tools used in new control methodologies to design nonlinear robust controller with an acceptable performance (e.g., minimum error, good trajectory, disturbance rejection).

Sliding mode controller (SMC) is a significant nonlinear controller under condition of partly uncertain dynamic parameters of system. This controller is used to control of highly nonlinear systems especially for robot manipulators, because this controller is a robust and stable [11-30]. Conversely, pure sliding mode controller is used in many applications; it has two important drawbacks namely; chattering phenomenon, and nonlinear equivalent dynamic formulation in uncertain dynamic parameter. The chattering phenomenon problem can be reduced by using linear saturation boundary layer function in sliding mode control law [31-50]. Lyapunov stability is proved in pure sliding mode controller based on switching (sign) function. The nonlinear

equivalent dynamic formulation problem in uncertain system can be solved by using artificial intelligence theorem or online tuning methodology. Fuzzy logic theory is used to estimate the system dynamic. However fuzzy logic controller is used to control complicated nonlinear dynamic systems, but it cannot guarantee stability and robustness. Pure sliding mode controller has difficulty in handling unstructured model uncertainties. It is possible to solve this problem by combining sliding mode controller and adaption law which this method can help improve the system's tracking performance by online tuning method [51-61].

Literature Review

Chattering phenomenon can cause some problems such as saturation and heats the mechanical parts of robot arm or drivers. To reduce or eliminate the oscillation, various papers have been reported by many researchers which one of the best methods is; boundary layer saturation method [1]. In boundary layer linear saturation method, the basic idea is the discontinuous method replacement by linear continuous saturation method with small neighborhood of the switching surface. This replacement caused considerable chattering reduction. Slotine and Sastry have introduced boundary layer method instead of discontinuous method to reduce the chattering [21]. Slotine has presented sliding mode controller with boundary layer to improve the industry application [22]. Palm has presented a fuzzy method to nonlinear approximation instead of linear approximation inside the boundary layer to improve the chattering and control the result performance [23]. Moreover, Weng and Yu improved the previous method by using a new method in fuzzy nonlinear approximation inside the boundary layer and adaptive method [24]. Control of robot arms using conventional controllers are based on robot arm dynamic modelling. These controllers often have many problems for modelling. Conventional controllers require accurate information of dynamic model of robot arms. When the system model is unknown or when it is known but complicated, it is difficult or impossible to use conventional mathematics to process this model [32]. In various dynamic parameters systems that need to be training on-line, adaptive control methodology is used. Mathematical model free adaptive method is used in systems which want to training parameters by performance knowledge. In this research in order to solve disturbance rejection and uncertainty dynamic parameter, adaptive method is applied to sliding mode controller. Mohan and Bhanot [40] have addressed comparative study between some adaptive fuzzy, and a new hybrid fuzzy control algorithm for robot arm control. They found that self-organizing fuzzy logic controller and proposed hybrid integrator fuzzy give the best performance as well as simple structure. Temeltas [46] has proposed fuzzy adaption techniques for VSC to achieve robust tracking of nonlinear systems and solves the chattering problem. Conversely system's performance is better than sliding mode controller; it is depended on nonlinear dynamic equation. Hwang *et al.* [47] have proposed a Tagaki-Sugeno (TS) fuzzy model based sliding mode controller based on N fuzzy based linear state-space to estimate the uncertainties. A MIMO FVSC reduces the chattering phenomenon and reconstructs the approximate the unknown system has been presented for a nonlinear system [42]. Yoo and Ham [58] have proposed a MIMO fuzzy system to help the compensation and estimation of the torque coupling. This method can only tune the consequence part of the fuzzy rules. Medhafer *et al.* [59] have proposed an indirect adaptive fuzzy sliding mode controller to control nonlinear system. This MIMO algorithm, applies to estimate the nonlinear dynamic parameters. Compared with the previous algorithm the numbers of fuzzy rules have reduced by introducing the sliding surface as inputs of fuzzy systems. Guo and Woo [60] have proposed a SISO fuzzy system compensate and reduce the chattering. Lin and Hsu [61] can tune both systems by fuzzy rules. Eksin *et al.* [83] have designed mathematical model-free sliding surface slope in fuzzy sliding mode controller. In above method researchers are used saturation function instead of switching function therefore the proof of stability is very difficult.

Problem Statements

One of the significant challenges in control algorithms is a linear behavior controller design for nonlinear systems (e.g., robot manipulator). Some of robot manipulators which work in industrial processes are controlled by linear PID controllers, but the design of linear controller for robot manipulators is extremely difficult because they are hardly nonlinear and uncertain [1-2, 6]. To reduce the above challenges, the nonlinear robust controller is used to control of robot

manipulator. Sliding mode controller is a powerful nonlinear robust controller under condition of partly uncertain dynamic parameters of system [7]. This controller is used to control of highly nonlinear systems especially for robot manipulators. Chattering phenomenon and nonlinear equivalent dynamic formulation in uncertain dynamic parameter are two main drawbacks in pure sliding mode controller [20]. The chattering phenomenon problem in pure sliding mode controller is reduced by using linear saturation boundary layer function but prove the stability is very difficult. In this research the nonlinear equivalent dynamic formulation problem and chattering phenomenon in uncertain system is solved by using on-line tuning theorem [8]. To estimate the system dynamics, mathematical error-based sliding mode controller is designed. Pure sliding mode controller has difficulty in handling unstructured model uncertainties. It is possible to solve this problem by combining sliding mode controller and mathematical error-based tuning. This method is based on resolve the on line sliding surface gain (λ) as well as improve the output performance by tuning the sliding surface slope updating factor (α). Mathematical error-based tuning sliding mode controllers is stable model-free controller and eliminates the chattering phenomenon without to use the boundary layer saturation function. Lyapunov stability is proved in mathematical error-based tuning fuzzy sliding mode controller based on switching (sign) function. Section 2, is served as an introduction to the sliding mode controller formulation algorithm and its application to control of robot manipulator. Part 3, introduces and describes the methodology (design mathematical error-based sliding mode controller) algorithms and proves Lyapunov stability. Section 4 presents the simulation results and discussion of this algorithm applied to a robot arm and the final section is describing the conclusion.

2. THEOREM: DYNAMIC FORMULATION OF ROBOTIC MANIPULATOR, SLIDING MODE FORMULATION APPLIED TO ROBOT ARM AND PROOF OF STABILITY

Dynamic of robot arm: The equation of an n -DOF robot manipulator governed by the following equation [1, 4, 15-29, 63-74]:

$$\mathbf{M}(q)\ddot{q} + \mathbf{N}(q, \dot{q}) = \tau \quad (1)$$

Where τ is actuation torque, $\mathbf{M}(q)$ is a symmetric and positive define inertia matrix, $\mathbf{N}(q, \dot{q})$ is the vector of nonlinearity term. This robot manipulator dynamic equation can also be written in a following form [1-29]:

$$\tau = \mathbf{M}(q)\ddot{q} + \mathbf{B}(q)[\dot{q} \dot{q}] + \mathbf{C}(q)[\dot{q}]^2 + \mathbf{G}(q) \quad (2)$$

Where $\mathbf{B}(q)$ is the matrix of coriolios torques, $\mathbf{C}(q)$ is the matrix of centrifugal torques, and $\mathbf{G}(q)$ is the vector of gravity force. The dynamic terms in equation (2) are only manipulator position. This is a decoupled system with simple second order linear differential dynamics. In other words, the component \ddot{q} influences, with a double integrator relationship, only the joint variable q_i , independently of the motion of the other joints. Therefore, the angular acceleration is found as to be [3, 41-62]:

$$\ddot{q} = \mathbf{M}^{-1}(q) \cdot \{\tau - \mathbf{N}(q, \dot{q})\} \quad (3)$$

This technique is very attractive from a control point of view.

Sliding Mode methodology: Consider a nonlinear single input dynamic system is defined by [6]:

$$\mathbf{x}^{(n)} = \mathbf{f}(\tilde{\mathbf{x}}) + \mathbf{b}(\tilde{\mathbf{x}})\mathbf{u} \quad (4)$$

Where \mathbf{u} is the vector of control input, $\mathbf{x}^{(n)}$ is the n^{th} derivation of \mathbf{x} , $\mathbf{x} = [\mathbf{x}, \dot{\mathbf{x}}, \ddot{\mathbf{x}}, \dots, \mathbf{x}^{(n-1)}]^T$ is the state vector, $\mathbf{f}(\mathbf{x})$ is unknown or uncertainty, and $\mathbf{b}(\mathbf{x})$ is of known *sign* function. The main goal to design this controller is train to the desired state; $\mathbf{x}_d = [\mathbf{x}_d, \dot{\mathbf{x}}_d, \ddot{\mathbf{x}}_d, \dots, \mathbf{x}_d^{(n-1)}]^T$, and trucking error vector is defined by [6]:

$$\tilde{\mathbf{x}} = \mathbf{x} - \mathbf{x}_d = [\tilde{\mathbf{x}}, \dots, \tilde{\mathbf{x}}^{(n-1)}]^T \quad (5)$$

A time-varying sliding surface $s(\mathbf{x}, t)$ in the state space \mathbf{R}^n is given by [6]:

$$s(x, t) = \left(\frac{d}{dt} + \lambda\right)^{n-1} \tilde{x} = 0 \quad (6)$$

where λ is the positive constant. To further penalize tracking error, integral part can be used in sliding surface part as follows [6]:

$$s(x, t) = \left(\frac{d}{dt} + \lambda\right)^{n-1} \left(\int_0^t \tilde{x} dt\right) = 0 \quad (7)$$

The main target in this methodology is kept the sliding surface slope $s(x, t)$ near to the zero. Therefore, one of the common strategies is to find input U outside of $s(x, t)$ [6].

$$\frac{1}{2} \frac{d}{dt} s^2(x, t) \leq -\zeta |s(x, t)| \quad (8)$$

where ζ is positive constant.

$$\text{If } S(0) > 0 \rightarrow \frac{d}{dt} S(t) \leq -\zeta \quad (9)$$

To eliminate the derivative term, it is used an integral term from $t=0$ to $t=t_{reach}$

$$\int_{t=0}^{t=t_{reach}} \frac{d}{dt} S(t) \leq - \int_{t=0}^{t=t_{reach}} \eta \rightarrow S(t_{reach}) - S(0) \leq -\zeta(t_{reach} - 0) \quad (10)$$

Where t_{reach} is the time that trajectories reach to the sliding surface so, suppose $S(t_{reach} = 0)$ defined as

$$0 - S(0) \leq -\eta(t_{reach}) \rightarrow t_{reach} \leq \frac{S(0)}{\zeta} \quad (11)$$

and

$$\text{if } S(0) < 0 \rightarrow 0 - S(0) \leq -\eta(t_{reach}) \rightarrow S(0) \leq -\zeta(t_{reach}) \rightarrow t_{reach} \leq \frac{|S(0)|}{\eta} \quad (12)$$

Equation (12) guarantees time to reach the sliding surface is smaller than $\frac{|S(0)|}{\zeta}$ since the trajectories are outside of $S(t)$.

$$\text{if } S_{t_{reach}} = S(0) \rightarrow \text{error}(x - x_d) = 0 \quad (13)$$

suppose S is defined as

$$s(x, t) = \left(\frac{d}{dt} + \lambda\right) \tilde{x} = (\dot{x} - \dot{x}_d) + \lambda(x - x_d) \quad (14)$$

The derivation of S , namely, \dot{S} can be calculated as the following;

$$\dot{S} = (\ddot{x} - \ddot{x}_d) + \lambda(\dot{x} - \dot{x}_d) \quad (15)$$

suppose the second order system is defined as;

$$\ddot{x} = f + u \rightarrow \dot{S} = f + U - \ddot{x}_d + \lambda(\dot{x} - \dot{x}_d) \quad (16)$$

Where f is the dynamic uncertain, and also since $S = 0$ and $\dot{S} = 0$, to have the best approximation, \hat{U} is defined as

$$\hat{U} = -\hat{f} + \ddot{x}_d - \lambda(\dot{x} - \dot{x}_d) \quad (17)$$

A simple solution to get the sliding condition when the dynamic parameters have uncertainty is the switching control law:

$$U_{dis} = \hat{U} - K(\tilde{x}, t) \cdot \text{sgn}(s) \quad (18)$$

where the switching function $\text{sgn}(S)$ is defined as [1, 6]

$$\text{sgn}(s) = \begin{cases} 1 & s > 0 \\ -1 & s < 0 \\ 0 & s = 0 \end{cases} \quad (19)$$

and the $K(\tilde{x}, t)$ is the positive constant. Suppose by (8) the following equation can be written as,

$$\frac{1}{2} \frac{d}{dt} s^2(x, t) = \dot{S} \cdot S = [f - \hat{f} - K \text{sgn}(s)] \cdot S = (f - \hat{f}) \cdot S - K|S| \quad (20)$$

and if the equation (12) instead of (11) the sliding surface can be calculated as

$$s(x, t) = \left(\frac{d}{dt} + \lambda \right)^2 \left(\int_0^t \tilde{x} dt \right) = (\dot{x} - \dot{x}_d) + 2\lambda(\dot{x} - \dot{x}_d) - \lambda^2(x - x_d) \quad (21)$$

in this method the approximation of U is computed as [6]

$$\hat{U} = -\hat{f} + \ddot{x}_d - 2\lambda(\dot{x} - \dot{x}_d) + \lambda^2(x - x_d) \quad (22)$$

Based on above discussion, the sliding mode control law for a multi degrees of freedom robot manipulator is written as [1, 6]:

$$\tau = \tau_{eq} + \tau_{dis} \quad (23)$$

Where, the model-based component τ_{eq} is the nominal dynamics of systems and τ_{eq} for first 3 DOF PUMA robot manipulator can be calculate as follows [1]:

$$\tau_{eq} = [M^{-1}(B + C + G) + \dot{S}]M \quad (24)$$

and τ_{dis} is computed as [1];

$$\tau_{dis} = K \cdot \text{sgn}(S) \quad (25)$$

by replace the formulation (25) in (23) the control output can be written as;

$$\tau = \tau_{eq} + K \cdot \text{sgn}(S) \quad (26)$$

By (26) and (24) the sliding mode control of PUMA 560 robot manipulator is calculated as;

$$\tau = [M^{-1}(B + C + G) + \dot{S}]M + K \cdot \text{sgn}(S) \quad (27)$$

where $S = \lambda e + \dot{e}$ in PD-SMC and $S = \lambda e + \dot{e} + \left(\frac{\lambda}{2}\right)^2 \int e$ in PID-SMC.

Proof of Stability: the lyapunov formulation can be written as follows,

$$V = \frac{1}{2} S^T \cdot M \cdot S \quad (28)$$

the derivation of V can be determined as,

$$\dot{V} = \frac{1}{2} S^T \cdot \dot{M} \cdot S + S^T M \dot{S} \quad (29)$$

the dynamic equation of IC engine can be written based on the sliding surface as

$$M\dot{S} = -VS + M\dot{S} + B + C + G \quad (30)$$

it is assumed that

$$S^T(\dot{M} - 2B + C + G)S = 0 \quad (31)$$

by substituting (30) in (29)

$$\dot{V} = \frac{1}{2} S^T \dot{M} S - S^T B + CS + S^T (M\dot{S} + B + CS + G) = S^T (M\dot{S} + B + CS + G) \quad (32)$$

suppose the control input is written as follows

$$\hat{U} = U_{\text{Nonlinear}} + \hat{U}_{dis} = [\hat{M}^{-1}(B + C + G) + \hat{S}] \hat{M} + K \cdot \text{sgn}(S) + B + CS + G \quad (33)$$

by replacing the equation (33) in (32)

$$\dot{V} = S^T (M\dot{S} + B + C + G - \hat{M}\dot{S} - \hat{B} + CS + G - K \text{sgn}(S)) = S^T (\tilde{M}\dot{S} + \tilde{B} + CS + G - K \text{sgn}(S)) \quad (34)$$

it is obvious that

$$|\widetilde{M}\dot{S} + \widetilde{B} + \widetilde{CS} + G| \leq |\widetilde{M}\dot{S}| + |\widetilde{B} + \widetilde{CS} + G| \tag{35}$$

the Lemma equation in robot arm system can be written as follows

$$K_u = [|\widetilde{M}\dot{S}| + |\widetilde{B} + \widetilde{CS} + G| + \eta]_i, i = 1, 2, 3, 4, \dots \tag{36}$$

the equation (11) can be written as

$$K_u \geq [|\widetilde{M}\dot{S} + \widetilde{B} + \widetilde{CS} + G|]_i + \eta_i \tag{37}$$

therefore, it can be shown that

$$\dot{V} \leq - \sum_{i=1}^n \eta_i |S_i| \tag{38}$$

Consequently the equation (38) guaranties the stability of the Lyapunov equation. Figure 1 is shown pure sliding mode controller, applied to robot arm.

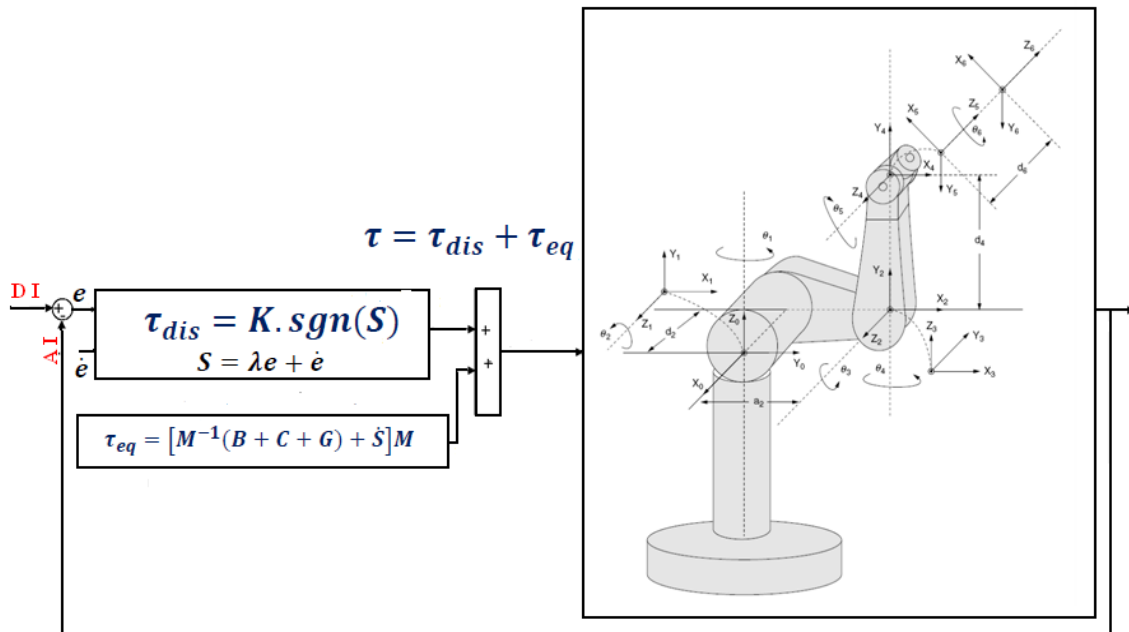

FIGURE 1: Block diagram of a sliding mode controller: applied to robot arm

2. METHODOLOGY: DESIGN MATHEMATICAL ERROR-BASED CHATTERING FREE SLIDING MODE CONTROLLER WITH SWITCHING FUNCTION

Sliding mode controller has difficulty in handling unstructured model uncertainties. It is possible to solve this problem by combining sliding mode controller and mathematical error-based tuning method which this method can helps to eliminate the chattering in presence of switching function method and improves the system's tracking performance by online tuning method. In this research the nonlinear equivalent dynamic (equivalent part) formulation problem in uncertain system is solved by using on-line mathematical error-based tuning theorem. In this method mathematical error-based theorem is applied to sliding mode controller to estimate the nonlinear equivalent part. Sliding mode controller has difficulty in handling unstructured model uncertainties and this controller's performance is sensitive to sliding surface slope coefficient. It is possible to solve above challenge by combining mathematical error-based tuning method and

sliding mode controller which this methodology can help to improve system's tracking performance by on-line tuning (mathematical error-based tuning) method. Based on above discussion, compute the best value of sliding surface slope coefficient has played important role to improve system's tracking performance especially when the system parameters are unknown or uncertain. This problem is solved by tuning the surface slope coefficient (λ) of the sliding mode controller continuously in real-time. In this methodology, the system's performance is improved with respect to the classical sliding mode controller. Figure 2 shows the mathematical error-based tuning sliding mode controller. Based on (23) and (27) to adjust the sliding surface slope coefficient we define $\hat{f}(x|\lambda)$ as the fuzzy based tuning.

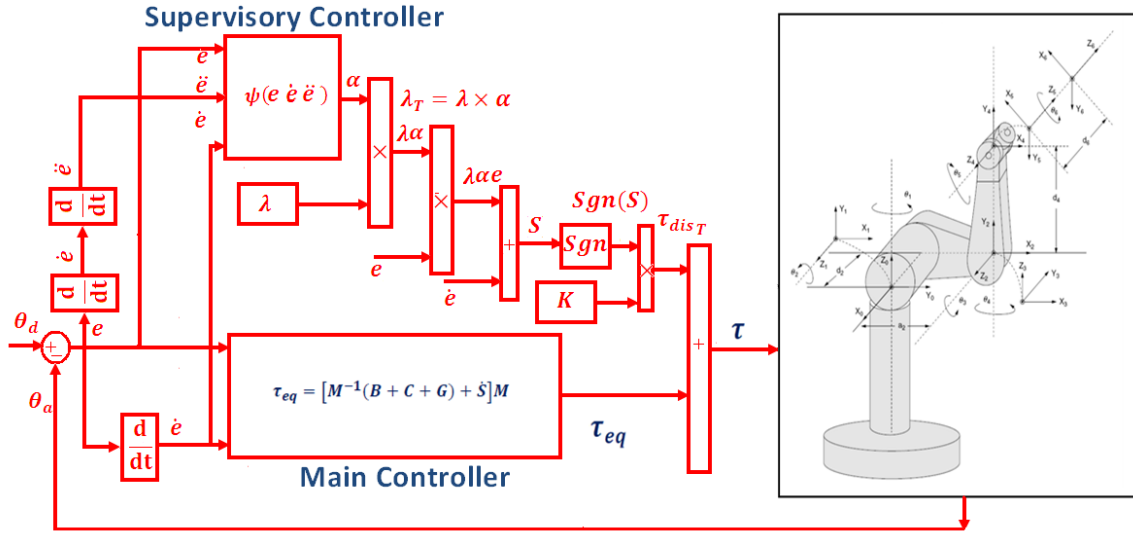

FIGURE 2: Block diagram of a mathematical error-based sliding mode controller: applied to robot arm

$$\hat{f}(x|\lambda) = \lambda^T \alpha \tag{39}$$

If minimum error (λ^*) is defined by;

$$\lambda^* = \mathbf{arg\ min} [(\mathbf{Sup})\{\hat{f}(x|\lambda) - f(x)\}] \tag{40}$$

Where λ^T is adjusted by an adaption law and this law is designed to minimize the error's parameters of $\lambda - \lambda^*$. adaption law in mathematical error-based tuning sliding mode controller is used to adjust the sliding surface slope coefficient. Mathematical error-based tuning part is a supervisory controller based on the following formulation methodology. This controller has three inputs namely; error (e), change of error (\dot{e}) and the second derivative of error (\ddot{e}) and an output namely; gain updating factor(α). As a summary design a mathematical error-based tuning is based on the following formulation:

$$\alpha = e^2 - \frac{((\frac{\ddot{e}(t)}{\dot{e}(*)}) - C)^5}{1+|e|} + C \tag{41}$$

$$\begin{aligned} \dot{e}(*) &= \dot{e}(t) \quad \text{if } \dot{e}(t) \geq \dot{e}(t-1) \\ \dot{e}(*) &= \dot{e}(t-1) \quad \text{if } \dot{e}(t-1) > \dot{e}(t) \end{aligned}$$

Where (α) is gain updating factor, (\ddot{e}) is the second derivative of error, (\dot{e}) is change of error, (e) is error and C is a coefficient.

Proof of Stability: The Lyapunov function in this design is defined as

$$V = \frac{1}{2} S^T M S + \frac{1}{2} \sum_{j=1}^M \frac{1}{\gamma_{sj}} \phi^T \cdot \phi_j \quad (42)$$

where γ_{sj} is a positive coefficient, $\phi = \lambda^* - \lambda$, θ^* is minimum error and λ is adjustable parameter.

Since $\dot{M} - 2V$ is skew-symmetric matrix;

$$S^T M \dot{S} + \frac{1}{2} S^T \dot{M} S = S^T (M \dot{S} + V S) \quad (43)$$

If the dynamic formulation of robot manipulator defined by

$$\tau = M(q)\ddot{q} + V(q, \dot{q})\dot{q} + G(q) \quad (44)$$

the controller formulation is defined by

$$\tau = \hat{M}\ddot{q}_r + \hat{V}\dot{q}_r + \hat{G} - \lambda S - K \quad (45)$$

According to (43) and (44)

$$M(q)\ddot{q} + V(q, \dot{q})\dot{q} + G(q) = \hat{M}\ddot{q}_r + \hat{V}\dot{q}_r + \hat{G} - \lambda S - K \quad (46)$$

Since $\dot{q}_r = \dot{q} - S$ and $\ddot{q}_r = \ddot{q} - \dot{S}$

$$M \dot{S} + (V + \lambda)S = \Delta f - K \quad (47)$$

$$M \dot{S} = \Delta f - K - V S - \lambda S$$

The derivation of V is defined

$$\dot{V} = S^T M \dot{S} + \frac{1}{2} S^T \dot{M} S + \sum_{j=1}^M \frac{1}{\gamma_{sj}} \phi^T \cdot \dot{\phi}_j \quad (48)$$

$$\dot{V} = S^T (M \dot{S} + V S) + \sum_{j=1}^M \frac{1}{\gamma_{sj}} \phi^T \cdot \dot{\phi}_j$$

Based on (46) and (47)

$$\dot{V} = S^T (\Delta f - K - V S - \lambda S + V S) + \sum_{j=1}^M \frac{1}{\gamma_{sj}} \phi^T \cdot \dot{\phi}_j \quad (49)$$

where $\Delta f = [M(q)\ddot{q} + V(q, \dot{q})\dot{q} + G(q)] - \sum_{i=1}^M \lambda^T \alpha$

$$\dot{V} = \sum_{j=1}^M [S_j(\Delta f_j - K_j)] - S^T \lambda S + \sum_{j=1}^M \frac{1}{\gamma_{sj}} \phi^T \cdot \dot{\phi}_j$$

suppose α is defined as follows

$$\alpha_j = e^2 - \frac{\left(\frac{\ddot{e}(t)}{\ddot{e}^*} - C\right)^5}{1 + |e|} + C \quad (50)$$

according to 48 and 49;

$$\dot{V} = \sum_{j=1}^M \left[S_j(\Delta f_j - \lambda^T [e^2 - \frac{\left(\frac{\ddot{e}(t)}{\ddot{e}^*} - C\right)^5}{1 + |e|} + C]) - S^T \lambda S + \sum_{j=1}^M \frac{1}{\gamma_{sj}} \phi^T \cdot \dot{\phi}_j \right] \quad (51)$$

Based on $\phi = \theta^* - \theta \rightarrow \dot{\phi} = -\dot{\theta}$

$$\begin{aligned} \dot{V} = \sum_{j=1}^M \left[S_j(\Delta f_j - \theta^{*T} [e^2 - \frac{((\ddot{e}(t)) - C)}{1 + |e|}] + C) + \phi^T [e^2 - \frac{((\ddot{e}(t)) - C)}{1 + |e|}] + C \right] - S^T \lambda S \quad (52) \\ + \sum_{j=1}^M \frac{1}{\gamma_{sj}} \phi^T \cdot \dot{\phi}_j \\ \dot{V} = \sum_{j=1}^M \left[S_j(\Delta f_j - (\lambda^*)^T [e^2 - \frac{((\ddot{e}(t)) - C)}{1 + |e|}] + C) \right] - S^T \lambda S + \sum_{j=1}^M \frac{1}{\gamma_{sj}} \phi_j^T [e^2 - \frac{((\ddot{e}(t)) - C)}{1 + |e|}] + C \\ + \dot{\phi}_j]) \end{aligned}$$

where $\dot{\theta}_j = e^2 - \frac{((\ddot{e}(t)) - C)}{1 + |e|} + C$ is adaption law, $\dot{\phi}_j = -\dot{\theta}_j = -[e^2 - \frac{((\ddot{e}(t)) - C)}{1 + |e|} + C]$

\dot{V} is considered by

$$\dot{V} = \sum_{j=1}^m [S_j \Delta f_j - \left((\lambda_j^*)^T e^2 - \frac{((\ddot{e}(t)) - C)}{1 + |e|} + C \right)] - S^T \lambda S \quad (53)$$

The minimum error is defined by

$$e_{mj} = \Delta f_j - \left((\lambda_j^*)^T e^2 - \frac{((\ddot{e}(t)) - C)}{1 + |e|} + C \right) \quad (54)$$

Therefore \dot{V} is computed as

$$\begin{aligned} \dot{V} &= \sum_{j=1}^m [S_j e_{mj}] - S^T \lambda S \quad (55) \\ &\leq \sum_{j=1}^m |S_j| |e_{mj}| - S^T \lambda S \\ &= \sum_{j=1}^m |S_j| |e_{mj}| - \lambda_j S_j^2 \\ &= \sum_{j=1}^m |S_j| (|e_{mj}| - \lambda_j S_j) \quad (56) \end{aligned}$$

For continuous function $g(x)$, and suppose $\epsilon > 0$ it is defined the fuzzy logic system in form of

$$\text{Sup}_{x \in U} |f(x) - g(x)| < \epsilon \quad (57)$$

the minimum approximation error (e_{mj}) is very small.

if $\lambda_j = \alpha$ that $\alpha |S_j| > e_{mj}$ ($S_j \neq 0$) then $\dot{V} < 0$ for ($S_j \neq 0$) (58)

3. RESULTS

Pure sliding mode controller has difficulty in handling unstructured model uncertainties. It is possible to solve this problem by combining sliding mode controller and mathematical error-based tuning in a single IC chip or combining sliding mode controller by fuzzy logic method (FSMC). These methods can improve the system's tracking performance by online tuning method or soft computing method. Proposed method is based on resolve the on line sliding surface slope as well

as improve the output performance by tuning the sliding surface slope coefficient. The sliding surface gain (λ) of this controller is adjusted online depending on the last values of error (e), change of error (\dot{e}) and power two of derivative of error (\ddot{e}) by sliding surface slope updating factor (α). Fuzzy sliding mode controller is based on applied fuzzy logic in sliding mode controller to estimate the dynamic formulation in equivalent part. Mathematical error-based tuning sliding mode controller is stable model-based controller which does not need to limits the dynamic model of robot manipulator and eliminate the chattering phenomenon without to use the boundary layer saturation function.

This section is focused on compare between Sliding Mode Controller (SMC), Fuzzy Sliding Mode Controller (FSMC) and mathematical error-based tuning Sliding Mode Controller (MTSMC). These controllers were tested by step responses. In this simulation, to control position of PUMA robot manipulator the first, second, and third joints are moved from home to final position without and with external disturbance. The simulation was implemented in Matlab/Simulink environment. **trajectory performance, torque performance, disturbance rejection, steady state error and RMS error** are compared in these controllers. These systems are tested by band limited white noise with a predefined 10%, 20% and 40% of relative to the input signal amplitude. This type of noise is used to external disturbance in continuous and hybrid systems and applied to nonlinear dynamic of these controllers.

Tracking Performances

Based on (27) in sliding mode controller; controllers performance are depended on the gain updating factor (K) and sliding surface slope coefficient (λ). These two coefficients are computed by trial and error in SMC. The best possible coefficients in step FSMC are; $K_p = K_v = K_i = 18$, $\phi_1 = \phi_2 = \phi_3 = 0.1$, and $\lambda_1 = 3, \lambda_2 = 6, \lambda_3 = 6$ and the best possible coefficients in step SMC are; $\lambda_1 = 1, \lambda_2 = 6, \lambda_3 = 8$; $K_p = K_v = K_i = 10$; $\phi_1 = \phi_2 = \phi_3 = 0.1$. In mathematical error-based tuning sliding mode controller the sliding surface gain is adjusted online depending on the last values of error (e), change of error (\dot{e}) and the second derivation of error (\ddot{e}) by sliding surface slope updating factor (α). Figure 3 shows tracking performance in mathematical error-based tuning sliding mode controller (MTSMC), fuzzy sliding mode controller (FSMC) and SMC without disturbance for step trajectory.

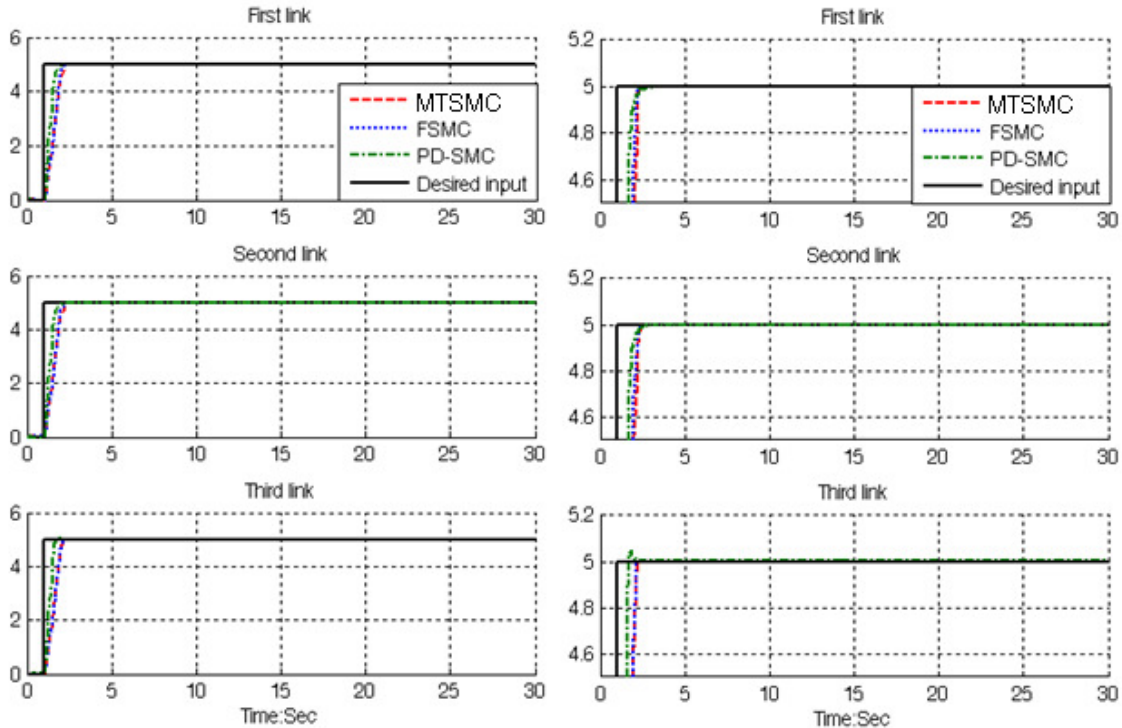

FIGURE 3 FSMC, MTSMC, desired input and SMC for first, second and third link step trajectory performance without disturbance

Based on Figure 3 it is observed that, the overshoot in MTSMC is 0%, in SMC's is 1% and in FSMC's is 0%, and rise time in MTSMC's is 0.6 seconds, in SMC's is 0.483 second and in FSMC's is about 0.6 seconds. From the trajectory MATLAB simulation for MTSMC, SMC and FSMC in certain system, it was seen that all of three controllers have acceptable performance.

Disturbance Rejection

Figures 4 to 6 show the power disturbance elimination in MTSMC, SMC and FSMC with disturbance for step trajectory. The disturbance rejection is used to test the robustness comparisons of these three controllers for step trajectory. A band limited white noise with predefined of 10%, 20% and 40% the power of input signal value is applied to the step trajectory. It found fairly fluctuations in SMC and FSMC trajectory responses.

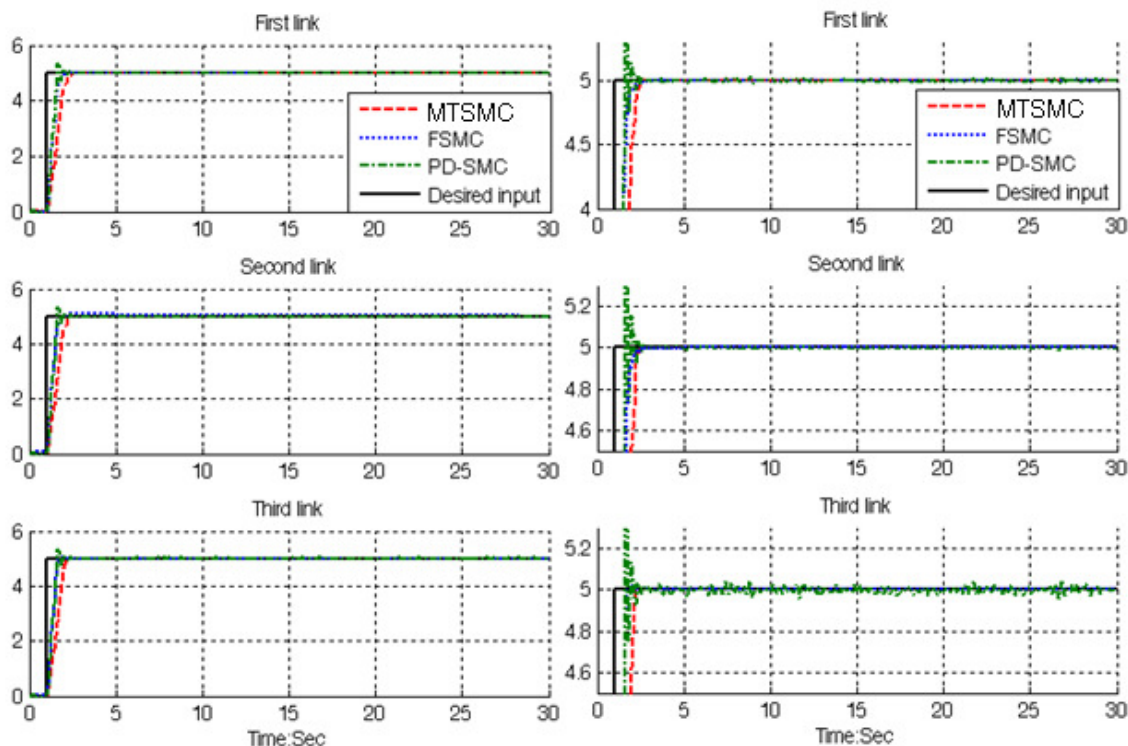

FIGURE 4 : Desired input, MTSMC, FSMC and SMC for first, second and third link trajectory with 10%external disturbance: step trajectory

Based on Figure 4; by comparing step response trajectory with 10% disturbance of relative to the input signal amplitude in MTSMC, FSMC and SMC, MTSMC's overshoot about (0%) is lower than FSMC's (0.5%) and SMC's (1%). SMC's rise time (0.5 seconds) is lower than FSMC's (0.63 second) and MTSMC's (0.65 second). Besides the Steady State and RMS error in MTSMC, FSMC and SMC it is observed that, error performances in MTSMC (Steady State error = $1.08e-12$ and RMS error= $1.5e-12$) are bout lower than FSMC (Steady State error = $1.08e-6$ and RMS error= $1.5e-6$) and SMC's (Steady State error= $1.6e-6$ and RMS error= $1.9e-6$).

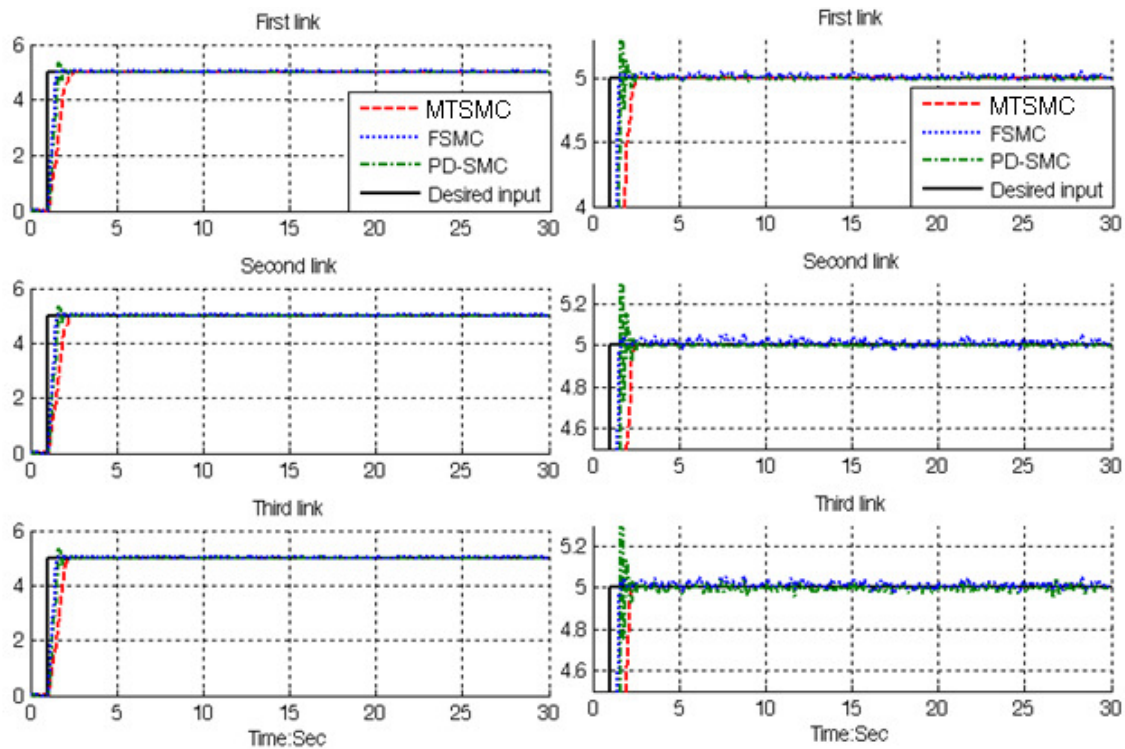

FIGURE 5: Desired input, MTSMC, FSMC and SMC for first, second and third link trajectory with 20%external disturbance: step trajectory

Based on Figure 5; by comparing step response trajectory with 20% disturbance of relative to the input signal amplitude in MTSMC, FSMC and SMC, MTSMC's overshoot about **(0%)** is lower than FSMC's **(1.8%)** and SMC's **(2.1%)**. SMC's rise time **(0.5 seconds)** is lower than FSMC's **(0.63 second)** and MTSMC's **(0.66 second)**. Besides the Steady State and RMS error in FTFSMC, FSMC and PD-SMC it is observed that, error performances in MTSMC **(Steady State error = $1.2e-12$ and RMS error= $1.8e-12$)** are about lower than FSMC **(Steady State error = $1.7e-5$ and RMS error= $2e-5$)** and SMC's **(Steady State error= $1.8e-5$ and RMS error= $2e-5$)**. Based on Figure 6, it was seen that, MTSMC's performance is better than FSMC and SMC because MTSMC can auto-tune the sliding surface slope coefficient as the dynamic manipulator parameter's change and in presence of external disturbance whereas FSMC and SMC cannot.

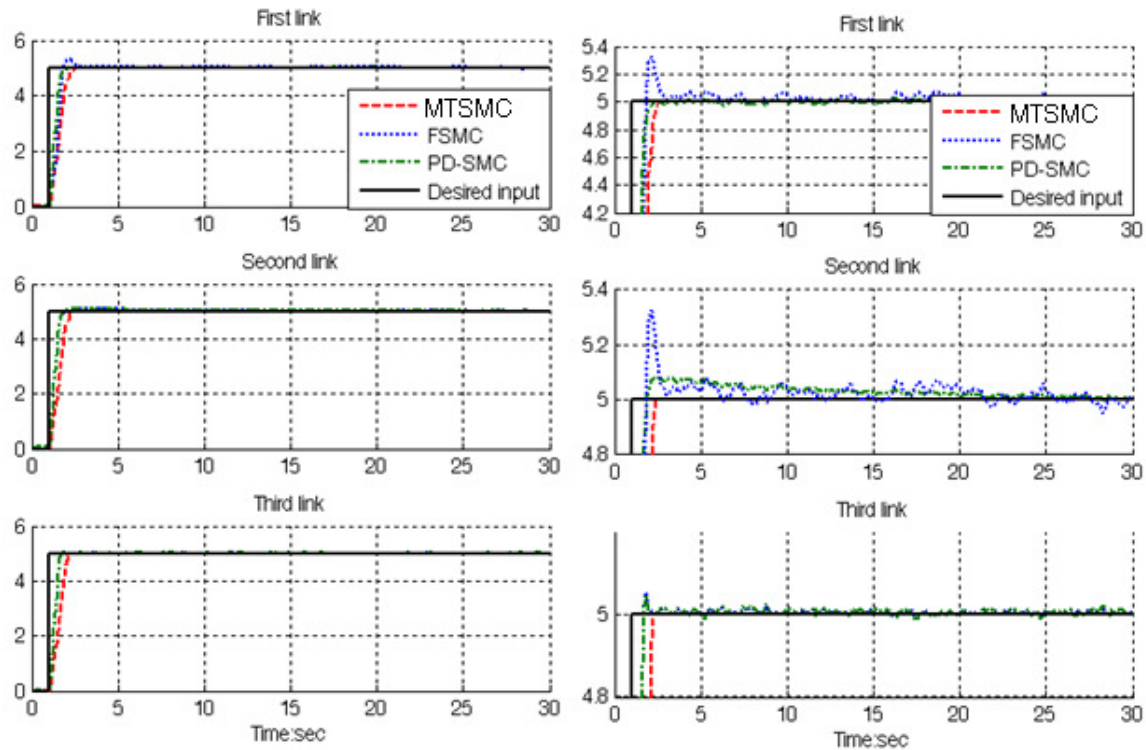

FIGURE 6 : Desired input, MTSMC, FSMC and SMC for first, second and third link trajectory with 40%external disturbance: step trajectory

Based on Figure 6; by comparing step response trajectory with 40% disturbance of relative to the input signal amplitude in MTSMC, SMC and FSMC, MTSMC's overshoot about **(0%)** is lower than FSMC's **(6%)** and PD-SMC's **(8%)**. SMC's rise time **(0.5 seconds)** is lower than FSMC's **(0.7 second)** and MTSMC's **(0.8 second)**. Besides the Steady State and RMS error in MTSMC, FSMC and SMC it is observed that, error performances in MTSMC **(Steady State error = $1.3e-12$ and RMS error= $1.8e-12$)** are about lower than FSMC **(Steady State error = $10e-4$ and RMS error= $0.69e-4$)** and SMC's **(Steady State error= $10e-4$ and RMS error= $11e-4$)**. Based on Figure 7, FSMC and SMC have moderately oscillation in trajectory response with regard to 40% of the input signal amplitude disturbance but MTSMC has stability in trajectory responses in presence of uncertainty and external disturbance. Based on Figure 6 in presence of 40% unstructured disturbance, MTSMC's is more robust than FSMC and SMC because MTSMC can auto-tune the sliding surface slope coefficient as the dynamic manipulator parameter's change and in presence of external disturbance whereas FSMC and SMC cannot.

Torque Performance

Figures 7 and 8 have indicated the power of chattering rejection in MTSMC, SMC and FSMC with 40% disturbance and without disturbance.

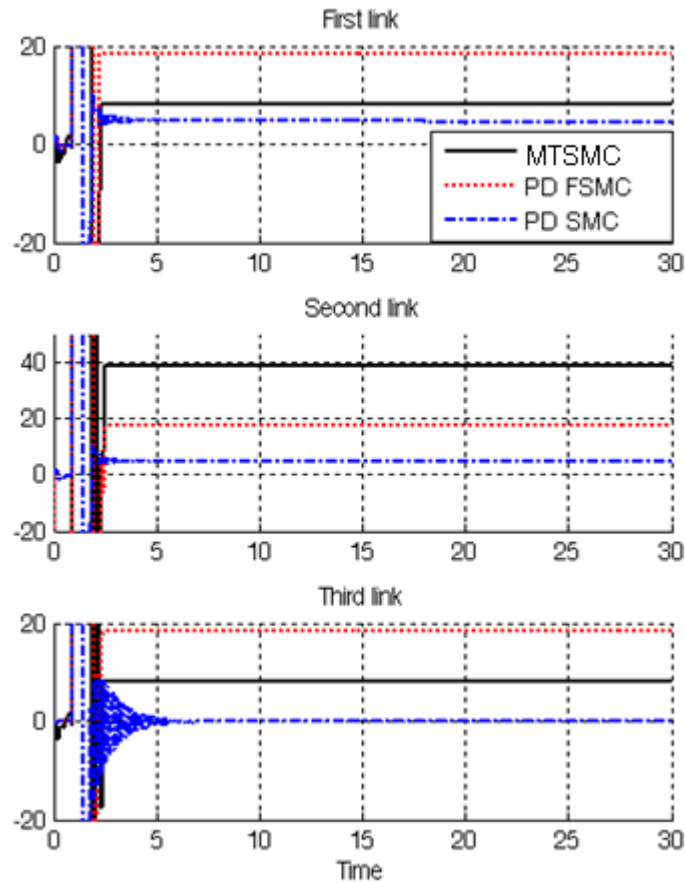

FIGURE 7 : MTSMC, SMC and FSMC for first, second and third link torque performance without disturbance

Figure 7 shows torque performance for first three links PUMA robot manipulator in MTSMC, SMC and FSMC without disturbance. Based on Figure 7, MTSMC, SMC and FSMC give considerable torque performance in certain system and all three of controllers eliminate the chattering phenomenon in certain system. Figure 8 has indicated the robustness in torque performance for first three links PUMA robot manipulator in MTSMC, SMC and FSMC in presence of 40% disturbance. Based on Figure 8, it is observed that SMC and FSMC controllers have oscillation but MTSMC has steady in torque performance. This is mainly because pure SMC with saturation function and fuzzy sliding mode controller with saturation function are robust but they have limitation in presence of external disturbance. The MTSMC gives significant chattering elimination when compared to FSMC and SMC. This elimination of chattering phenomenon is very significant in presence of 40% disturbance. This challenge is one of the most important objectives in this research.

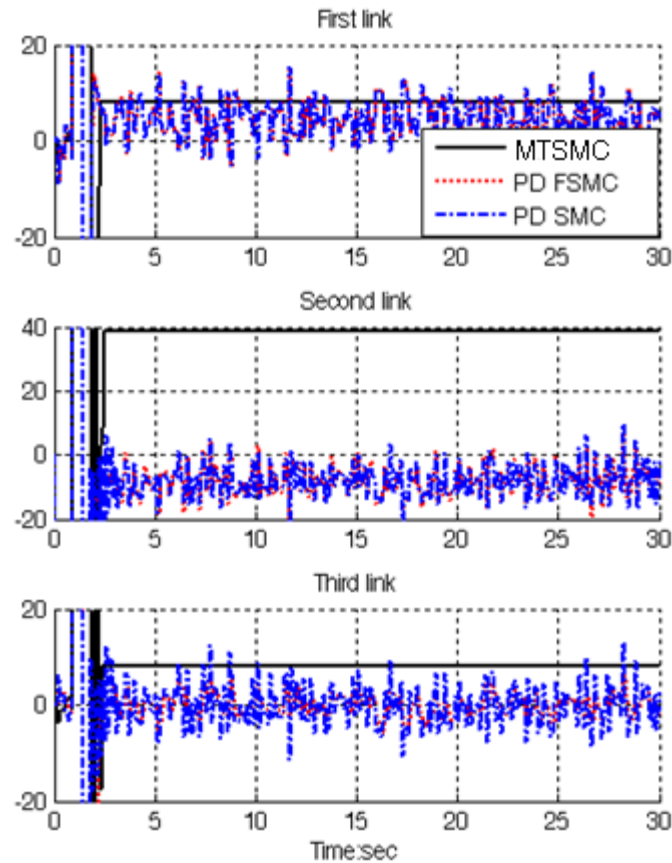

FIGURE 8: MTSMC, SMC and FSMC for first, second and third link torque performance with 40% disturbance

Based on Figure 8 it is observed that, however mathematical tuning error-based sliding mode controller (MTSMC) is a model-based controller that estimate the nonlinear dynamic equivalent formulation by system's performance but it has significant torque performance (chattering phenomenon) in presence of uncertainty and external disturbance. SMC and FSMC have limitation to eliminate the chattering in presence of highly external disturbance (e.g., 40% disturbance) but MTSMC is a robust against to highly external disturbance.

Steady State Error

Figure 9 is shown the error performance in MTSMC, SMC and FSMC for first three links of PUMA robot manipulator. The error performance is used to test the disturbance effect comparisons of these controllers for step trajectory. All three joint's inputs are step function with the same step time (step time= 1 second), the same initial value (initial value=0) and the same final value (final value=5). Based on Figure 4, MTSMC's rise time is about 0.6 second, SMC's rise time is about 0.483 second and FSMC's rise time is about 0.6 second which caused to create a needle wave in the range of 5 (amplitude=5) and the different width. In this system this time is transient time and this part of error introduced as a transient error. Besides the Steady State and RMS error in MTSMC, FSMC and SMC it is observed that, error performances in MTSMC (**Steady State error = $0.9e-12$ and RMS error= $1.1e-12$**) are about lower than FSMC (**Steady State error = $0.7e-8$ and RMS error= $1e-7$**) and SMC's (**Steady State error= $1e-8$ and RMS error= $1.2e-6$**).

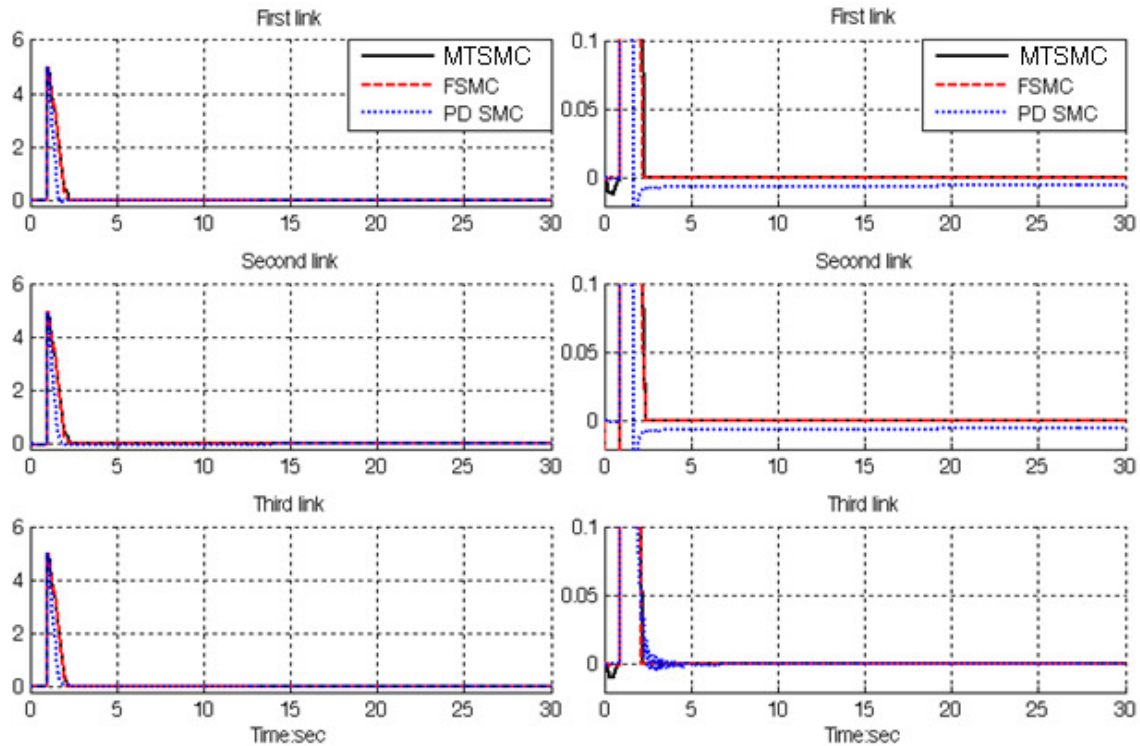

FIGURE 9 : MTSMC, SMC and FSMC for first, second and third link steady state error without disturbance: step trajectory

The MTSMC gives significant steady state error performance when compared to FSMC and SMC. When applied 40% disturbances in MTSMC the RMS error increased approximately 0.0164% (percent of increase the MTSMC RMS error = $\frac{(40\% \text{ disturbance RMS error})}{\text{no disturbance RMS error}} = \frac{1.8e-12}{1.1e-12} = 0.0164\%$), in FSMC the RMS error increased approximately 6.9% (percent of increase the FSMC RMS error = $\frac{(40\% \text{ disturbance RMS error})}{\text{no disturbance RMS error}} = \frac{0.69e-4}{1e-7} = 6.9\%$) in SMC the RMS error increased approximately 9.17% (percent of increase the PD-SMC RMS error = $\frac{(40\% \text{ disturbance RMS error})}{\text{no disturbance RMS error}} = \frac{11e-4}{1.2e-6} = 9.17\%$). In this part MTSMC, SMC and FSMC have been comparatively evaluation through MATLAB simulation, for PUMA robot manipulator control. It is observed that however MTSMC is independent of nonlinear dynamic equation of PUMA 560 robot manipulator but it can guarantee the trajectory following and eliminate the chattering phenomenon in certain systems, structure uncertain systems and unstructured model uncertainties by online tuning method.

4. CONCLUSION

Refer to this research, a mathematical error-based tuning sliding mode controller (MTSMC) is proposed for PUMA robot manipulator. Pure sliding mode controller with saturation function and fuzzy sliding mode controller with saturation function have difficulty in handling unstructured model uncertainties. It is possible to solve this problem by combining fuzzy sliding mode controller and mathematical error-based tuning. Since the sliding surface gain (λ) is adjusted by mathematical error-based tuning method, it is nonlinear and continuous. The sliding surface slope updating factor (α) of mathematical error-based tuning part can be changed with the changes in error, change of error and the second change of error. Sliding surface gain is adapted on-line by sliding surface slope updating factor. In pure sliding mode controller and fuzzy sliding mode controller the sliding surface gain is chosen by trial and error, which means pure sliding mode controller and error-based fuzzy sliding mode controller have to have a prior knowledge of the system uncertainty. If the knowledge is not available error performance and chattering

phenomenon are go up. In mathematical error-based tuning sliding mode controller the sliding surface gain are updated on-line to compensate the system unstructured uncertainty. The stability and convergence of the mathematical error-based tuning sliding mode controller based on switching function is guarantee and proved by the Lyapunov method. The simulation results exhibit that the mathematical error-based tuning sliding mode controller works well in various situations. Based on theoretical and simulation results, it is observed that mathematical error-based tuning sliding mode controller is a model-based stable control for robot manipulator. It is a best solution to eliminate chattering phenomenon with saturation function in structure and unstructured uncertainties.

REFERENCES

- [1] T. R. Kurfess, *Robotics and automation handbook*: CRC, 2005.
- [2] J. J. E. Slotine and W. Li, *Applied nonlinear control* vol. 461: Prentice hall Englewood Cliffs, NJ, 1991.
- [3] K. Ogata, *Modern control engineering*: Prentice Hall, 2009.
- [4] L. Cheng, Z. G. Hou, M. Tan, D. Liu and A. M. Zou, "Multi-agent based adaptive consensus control for multiple manipulators with kinematic uncertainties," 2008, pp. 189-194.
- [5] J. J. D'Azzo, C. H. Houpis and S. N. Sheldon, *Linear control system analysis and design with MATLAB*: CRC, 2003.
- [6] B. Siciliano and O. Khatib, *Springer handbook of robotics*: Springer-Verlag New York Inc, 2008.
- [7] I. Boiko, L. Fridman, A. Pisano and E. Usai, "Analysis of chattering in systems with second-order sliding modes," *IEEE Transactions on Automatic Control*, No. 11, vol. 52, pp. 2085-2102, 2007.
- [8] J. Wang, A. Rad and P. Chan, "Indirect adaptive fuzzy sliding mode control: Part I: fuzzy switching," *Fuzzy Sets and Systems*, No. 1, vol. 122, pp. 21-30, 2001.
- [9] C. Wu, "Robot accuracy analysis based on kinematics," *IEEE Journal of Robotics and Automation*, No. 3, vol. 2, pp. 171-179, 1986.
- [10] H. Zhang and R. P. Paul, "A parallel solution to robot inverse kinematics," *IEEE conference proceeding*, 2002, pp. 1140-1145.
- [11] J. Kieffer, "A path following algorithm for manipulator inverse kinematics," *IEEE conference proceeding*, 2002, pp. 475-480.
- [12] Z. Ahmad and A. Guez, "On the solution to the inverse kinematic problem(of robot)," *IEEE conference proceeding*, 1990, pp. 1692-1697.
- [13] F. T. Cheng, T. L. Hour, Y. Y. Sun and T. H. Chen, "Study and resolution of singularities for a 6-DOF PUMA manipulator," *Systems, Man, and Cybernetics, Part B: Cybernetics, IEEE Transactions on*, No. 2, vol. 27, pp. 332-343, 2002.
- [14] M. W. Spong and M. Vidyasagar, *Robot dynamics and control*: Wiley-India, 2009.
- [15] A. Vivas and V. Mosquera, "Predictive functional control of a PUMA robot," *Conference Proceedings*, 2005.

- [16] D. Nguyen-Tuong, M. Seeger and J. Peters, "Computed torque control with nonparametric regression models," *IEEE conference proceeding*, 2008, pp. 212-217.
- [17] V. Utkin, "Variable structure systems with sliding modes," *Automatic Control, IEEE Transactions on*, No. 2, vol. 22, pp. 212-222, 2002.
- [18] R. A. DeCarlo, S. H. Zak and G. P. Matthews, "Variable structure control of nonlinear multivariable systems: a tutorial," *Proceedings of the IEEE*, No. 3, vol. 76, pp. 212-232, 2002.
- [19] K. D. Young, V. Utkin and U. Ozguner, "A control engineer's guide to sliding mode control," *IEEE conference proceeding*, 2002, pp. 1-14.
- [20] O. Kaynak, "Guest editorial special section on computationally intelligent methodologies and sliding-mode control," *IEEE Transactions on Industrial Electronics*, No. 1, vol. 48, pp. 2-3, 2001.
- [21] J. J. Slotine and S. Sastry, "Tracking control of non-linear systems using sliding surfaces, with application to robot manipulators†," *International Journal of Control*, No. 2, vol. 38, pp. 465-492, 1983.
- [22] J. J. E. Slotine, "Sliding controller design for non-linear systems," *International Journal of Control*, No. 2, vol. 40, pp. 421-434, 1984.
- [23] R. Palm, "Sliding mode fuzzy control," *IEEE conference proceeding*, 2002, pp. 519-526.
- [24] C. C. Weng and W. S. Yu, "Adaptive fuzzy sliding mode control for linear time-varying uncertain systems," *IEEE conference proceeding*, 2008, pp. 1483-1490.
- [25] M. Ertugrul and O. Kaynak, "Neuro sliding mode control of robotic manipulators," *Mechatronics Journal*, No. 1, vol. 10, pp. 239-263, 2000.
- [26] P. Kachroo and M. Tomizuka, "Chattering reduction and error convergence in the sliding-mode control of a class of nonlinear systems," *Automatic Control, IEEE Transactions on*, No. 7, vol. 41, pp. 1063-1068, 2002.
- [27] H. Elmali and N. Olgac, "Implementation of sliding mode control with perturbation estimation (SMCPE)," *Control Systems Technology, IEEE Transactions on*, No. 1, vol. 4, pp. 79-85, 2002.
- [28] J. Moura and N. Olgac, "A comparative study on simulations vs. experiments of SMCPE," *IEEE conference proceeding*, 2002, pp. 996-1000.
- [29] Y. Li and Q. Xu, "Adaptive Sliding Mode Control With Perturbation Estimation and PID Sliding Surface for Motion Tracking of a Piezo-Driven Micromanipulator," *Control Systems Technology, IEEE Transactions on*, No. 4, vol. 18, pp. 798-810, 2010.
- [30] B. Wu, Y. Dong, S. Wu, D. Xu and K. Zhao, "An integral variable structure controller with fuzzy tuning design for electro-hydraulic driving Stewart platform," *IEEE conference proceeding*, 2006, pp. 5-945.
- [31] Farzin Piltan , N. Sulaiman, Zahra Tajpaykar, Payman Ferdosali, Mehdi Rashidi, "Design Artificial Nonlinear Robust Controller Based on CTLC and FSMC with Tunable Gain," *International Journal of Robotic and Automation*, 2 (3): 205-220, 2011.

- [32] Farzin Piltan, A. R. Salehi and Nasri B Sulaiman.,” Design artificial robust control of second order system based on adaptive fuzzy gain scheduling,” world applied science journal (WASJ), 13 (5): 1085-1092, 2011
- [33] Farzin Piltan, N. Sulaiman, Atefeh Gavahian, Samira Soltani, Samaneh Roosta, “Design Mathematical Tunable Gain PID-Like Sliding Mode Fuzzy Controller with Minimum Rule Base,” International Journal of Robotic and Automation, 2 (3): 146-156, 2011.
- [34] Farzin Piltan , A. Zare, Nasri B. Sulaiman, M. H. Marhaban and R. Ramli, , “A Model Free Robust Sliding Surface Slope Adjustment in Sliding Mode Control for Robot Manipulator,” World Applied Science Journal, 12 (12): 2330-2336, 2011.
- [35] Farzin Piltan , A. H. Aryanfar, Nasri B. Sulaiman, M. H. Marhaban and R. Ramli “Design Adaptive Fuzzy Robust Controllers for Robot Manipulator,” World Applied Science Journal, 12 (12): 2317-2329, 2011.
- [36] Farzin Piltan, N. Sulaiman , Arash Zargari, Mohammad Keshavarz, Ali Badri , “Design PID-Like Fuzzy Controller With Minimum Rule Base and Mathematical Proposed On-line Tunable Gain: Applied to Robot Manipulator,” International Journal of Artificial intelligence and expert system, 2 (4):184-195, 2011.
- [37] Farzin Piltan, Nasri Sulaiman, M. H. Marhaban and R. Ramli, “Design On-Line Tunable Gain Artificial Nonlinear Controller,” Journal of Advances In Computer Research, 2 (4): 75-83, 2011.
- [38] Farzin Piltan, N. Sulaiman, Payman Ferdosali, Iraj Assadi Talooki, “ Design Model Free Fuzzy Sliding Mode Control: Applied to Internal Combustion Engine,” International Journal of Engineering, 5 (4):302-312, 2011.
- [39] Farzin Piltan, N. Sulaiman, Samaneh Roosta, M.H. Marhaban, R. Ramli, “Design a New Sliding Mode Adaptive Hybrid Fuzzy Controller,” Journal of Advanced Science & Engineering Research , 1 (1): 115-123, 2011.
- [40] Farzin Piltan, Atefe Gavahian, N. Sulaiman, M.H. Marhaban, R. Ramli, “Novel Sliding Mode Controller for robot manipulator using FPGA,” Journal of Advanced Science & Engineering Research, 1 (1): 1-22, 2011.
- [41] Farzin Piltan, N. Sulaiman, A. Jalali & F. Danesh Narouei, “Design of Model Free Adaptive Fuzzy Computed Torque Controller: Applied to Nonlinear Second Order System,” International Journal of Robotics and Automation, 2 (4):232-244, 2011.
- [42] Farzin Piltan, N. Sulaiman, Iraj Asadi Talooki, Payman Ferdosali, “Control of IC Engine: Design a Novel MIMO Fuzzy Backstepping Adaptive Based Fuzzy Estimator Variable Structure Control ,” International Journal of Robotics and Automation, 2 (5):360-380, 2011.
- [43] Farzin Piltan, N. Sulaiman, Payman Ferdosali, Mehdi Rashidi, Zahra Tajpeikar, “Adaptive MIMO Fuzzy Compensate Fuzzy Sliding Mode Algorithm: Applied to Second Order Nonlinear System,” International Journal of Engineering, 5 (5): 380-398, 2011.
- [44] Farzin Piltan, N. Sulaiman, Hajar Nasiri, Sadeq Allahdadi, Mohammad A. Bairami, “Novel Robot Manipulator Adaptive Artificial Control: Design a Novel SISO Adaptive Fuzzy Sliding Algorithm Inverse Dynamic Like Method,” International Journal of Engineering, 5 (5): 399-418, 2011.

- [45] Farzin Piltan, N. Sulaiman, Sadeq Allahdadi, Mohammadali Dialame, Abbas Zare, "Position Control of Robot Manipulator: Design a Novel SISO Adaptive Sliding Mode Fuzzy PD Fuzzy Sliding Mode Control," *International Journal of Artificial intelligence and Expert System*, 2 (5):208-228, 2011.
- [46] Farzin Piltan, SH. Tayebi HAGHIGHI, N. Sulaiman, Iman Nazari, Sobhan Siamak, "Artificial Control of PUMA Robot Manipulator: A-Review of Fuzzy Inference Engine And Application to Classical Controller ," *International Journal of Robotics and Automation*, 2 (5):401-425, 2011.
- [47] Farzin Piltan, N. Sulaiman, Abbas Zare, Sadeq Allahdadi, Mohammadali Dialame, "Design Adaptive Fuzzy Inference Sliding Mode Algorithm: Applied to Robot Arm," *International Journal of Robotics and Automation* , 2 (5): 283-297, 2011.
- [48] Farzin Piltan, Amin Jalali, N. Sulaiman, Atefeh Gavahian, Sobhan Siamak, "Novel Artificial Control of Nonlinear Uncertain System: Design a Novel Modified PSO SISO Lyapunov Based Fuzzy Sliding Mode Algorithm ," *International Journal of Robotics and Automation*, 2 (5): 298-316, 2011.
- [49] Farzin Piltan, N. Sulaiman, Amin Jalali, Koorosh Aslansefat, "Evolutionary Design of Mathematical tunable FPGA Based MIMO Fuzzy Estimator Sliding Mode Based Lyapunov Algorithm: Applied to Robot Manipulator," *International Journal of Robotics and Automation*, 2 (5):317-343, 2011.
- [50] Farzin Piltan, N. Sulaiman, Samaneh Roosta, Atefeh Gavahian, Samira Soltani, "Evolutionary Design of Backstepping Artificial Sliding Mode Based Position Algorithm: Applied to Robot Manipulator," *International Journal of Engineering*, 5 (5):419-434, 2011.
- [51] Farzin Piltan, N. Sulaiman, S.Soltani, M. H. Marhaban & R. Ramli, "An Adaptive sliding surface slope adjustment in PD Sliding Mode Fuzzy Control for Robot Manipulator," *International Journal of Control and Automation* , 4 (3): 65-76, 2011.
- [52] Farzin Piltan, N. Sulaiman, Mehdi Rashidi, Zahra Tajpaikar, Payman Ferdosali, "Design and Implementation of Sliding Mode Algorithm: Applied to Robot Manipulator-A Review ," *International Journal of Robotics and Automation*, 2 (5):265-282, 2011.
- [53] Farzin Piltan, N. Sulaiman, Amin Jalali, Sobhan Siamak, and Iman Nazari, "Control of Robot Manipulator: Design a Novel Tuning MIMO Fuzzy Backstepping Adaptive Based Fuzzy Estimator Variable Structure Control ," *International Journal of Control and Automation*, 4 (4):91-110, 2011.
- [54] Farzin Piltan, N. Sulaiman, Atefeh Gavahian, Samaneh Roosta, Samira Soltani, "On line Tuning Premise and Consequence FIS: Design Fuzzy Adaptive Fuzzy Sliding Mode Controller Based on Lyapunov Theory," *International Journal of Robotics and Automation*, 2 (5):381-400, 2011.
- [55] Farzin Piltan, N. Sulaiman, Samaneh Roosta, Atefeh Gavahian, Samira Soltani, "Artificial Chattering Free on-line Fuzzy Sliding Mode Algorithm for Uncertain System: Applied in Robot Manipulator," *International Journal of Engineering*, 5 (5):360-379, 2011.
- [56] Farzin Piltan, N. Sulaiman and I.AsadiTalooki, "Evolutionary Design on-line Sliding Fuzzy Gain Scheduling Sliding Mode Algorithm: Applied to Internal Combustion Engine," *International Journal of Engineering Science and Technology*, 3 (10):7301-7308, 2011.

- [57] Farzin Piltan, Nasri B Sulaiman, Iraj Asadi Talooki and Payman Ferdosali., " Designing On-Line Tunable Gain Fuzzy Sliding Mode Controller Using Sliding Mode Fuzzy Algorithm: Applied to Internal Combustion Engine," *world applied science journal (WASJ)*, 15 (3): 422-428, 2011
- [58] B. K. Yoo and W. C. Ham, "Adaptive control of robot manipulator using fuzzy compensator," *Fuzzy Systems, IEEE Transactions on*, No. 2, vol. 8, pp. 186-199, 2002.
- [59] H. Medhaffar, N. Derbel and T. Damak, "A decoupled fuzzy indirect adaptive sliding mode controller with application to robot manipulator," *International Journal of Modelling, Identification and Control*, No. 1, vol. 1, pp. 23-29, 2006.
- [60] Y. Guo and P. Y. Woo, "An adaptive fuzzy sliding mode controller for robotic manipulators," *Systems, Man and Cybernetics, Part A: Systems and Humans, IEEE Transactions on*, No. 2, vol. 33, pp. 149-159, 2003.
- [61] C. M. Lin and C. F. Hsu, "Adaptive fuzzy sliding-mode control for induction servomotor systems," *Energy Conversion, IEEE Transactions on*, No. 2, vol. 19, pp. 362-368, 2004.
- [62] Xiaosong. Lu, "An investigation of adaptive fuzzy sliding mode control for robot manipulator," *Carleton university Ottawa*, 2007.
- [63] S. Lentijo, S. Pytel, A. Monti, J. Hudgins, E. Santi and G. Simin, "FPGA based sliding mode control for high frequency power converters," *IEEE Conference*, 2004, pp. 3588-3592.
- [64] B. S. R. Armstrong, "Dynamics for robot control: friction modeling and ensuring excitation during parameter identification," 1988.
- [65] C. L. Clover, "Control system design for robots used in simulating dynamic force and moment interaction in virtual reality applications," 1996.
- [66] K. R. Horspool, *Cartesian-space Adaptive Control for Dual-arm Force Control Using Industrial Robots*: University of New Mexico, 2003.
- [67] B. Armstrong, O. Khatib and J. Burdick, "The explicit dynamic model and inertial parameters of the PUMA 560 arm," *IEEE Conference*, 2002, pp. 510-518.
- [68] P. I. Corke and B. Armstrong-Helouvry, "A search for consensus among model parameters reported for the PUMA 560 robot," *IEEE Conference*, 2002, pp. 1608-1613.
- [69] Farzin Piltan, N. Sulaiman, M. H. Marhaban, Adel Nowzary, Mostafa Tohidian, "Design of FPGA based sliding mode controller for robot manipulator," *International Journal of Robotic and Automation*, 2 (3): 183-204, 2011.
- [70] I. Eksin, M. Guzelkaya and S. Tokat, "Sliding surface slope adjustment in fuzzy sliding mode controller," *Mediterranean Conference*, 2002, pp. 160-168.