

Chopper Control of a Bipolar Stepper Motor

Maher Dababneh

*Electrical Engineering Department
Isra University
11622 Amman, Jordan*

mikemaher_1@hotmail.co.uk

Walid Emar

*Electrical Engineering Department
Isra University
11622 Amman, Jordan*

walidemar@yahoo.com

Issam TTrad

*Faculty of science and information
Jadara University
Irbid, Jordan*

Issam_161@yahoo.com

Abstract

Low power stepper motors, such as those used in floppy disk drives, are usually powered at low dc voltages, and the value of the motor windings current is usually restricted by the internal resistance of the winding. Very low resistance windings are usually used for building high torque motors; when powered by any suitable supply voltage, these motors typically require external current limiting circuitry.

The requirements for stepper motor drive circuits have changed at a very rapid rate and hence digital integrated circuits have been developed to avoid any complexity and provide facilities to be used in association with microcontrollers. The reduction of discrete circuit components has enhanced the reliability and permitted the use of more sophisticated drive techniques at a reasonable cost [1].

The rotor of a stepper motor usually aligns itself with the stator magnetic field generated by a dc current applied to the stator coils. When the rotor is driven by an external force, a restoring torque is developed. The torque becomes maximum when the rotor is turned by one step angle on either direction. This maximum torque is called the holding torque and has the unit of ounce-inches (oz-inches). It may be good to say that the running torque or the pull-out torque should be less than the holding torque; otherwise the rotor will not turn. The pull-out torque is the true indication of the torque output capability of the motor. This torque varies with the stepping rate or rotor speed [1-2].

Thus the running torque of stepper motor may be considered as the peak load torque that can be subjected to the motor without affecting the rotor equilibrium position while the appropriate stator windings are energized.

The dynamic characteristics and efficiency of the stepper motor drive may be improved if a steady dc current switched mode power supply is used. This paper discusses two types of power electronic circuits for limiting the current through the windings of the stepper motor. These two current limiters are suitable for many other industrial applications, including limiting the current rise and decrease through the dc motor windings and other highly inductive loads. This paper also covers the basic principles of stepper motors and stepper motor control systems. It focuses on a Bipolar permanent magnet, from the elementary circuitry needed to control its speed, to the methods used for improving its time constant and stepper rate [1-5].

Keywords: Stepper Motor, Bipolar Permanent Magnet, Time Constant, Chopper Converter, Chopper Control.

1. INTRODUCTION

The stepper motor is an incremental drive actuator or in other words it is an electromechanical device which actuates a train of step angular movements in response to a train of input pulses on a one-to-one basis. This means that the motor moves one step for one input pulse. It is a digitally controlled motor and the rotational speed is determined by the frequency of the applied pulses and hence the response speed is high. This motor can be rotated in either direction, clockwise or anticlockwise by changing the sequence of pulses of the drive circuit to its stator windings. The basic feature of the stepper motor is that, when it is energized it will move and come to rest after some number of steps in strict accordance with the digital input commands provided. Thus, the stepper motor can control the velocity, direction and distance of the load. The error which can be introduced in the system where a stepper motor is used is a small percentage of one step and is non cumulative irrespective of the distance travelled or the number of times responding takes place.

Owing to the above good features, the applications of the stepper motor are increasing day by day. The main applications are in the fields of numerical control of machines such as milling machines, lathes, CNC systems, robotics, etc. They are extensively used in computer peripherals and in electronic clocks and watches, photo printing machines, in digital cameras [1].

When a stepper motor is energized by a steady *dc* current applied to its specified stator coils the rotor lines up with the stator fields. If the rotor is turned by an external force, a restoring torque is developed. The torque becomes maximum when the rotor is turned by one step angle on either direction. This maximum value of the torque is called the holding torque and is measured in ounce-inches (oz-inches). It may be mentioned that the running torque or the pull-out torque must be less than the holding torque, otherwise the rotor will not turn.

The permanent magnet motors have also a torque even when the stator is not energized, due to the *détente* torque. The *détente* torque defined as the maximum load torque that can be applied to the unexcited motor without causing the rotor to move from the stable equilibrium position. And it is less in value than the holding torque.

It is known that the basic problem for the drive of a stepper motor lies in the inductance of the stator winding. The time constant of the windings prevents the current to follow the winding voltage pulse. The current rises slowly and does not reach the full rated value, particularly at high speed. As a result the torque decreases with increasing pulse rate. The torque-speed performance can be improved by any of the following methods:

1. By increasing stator coil resistance through connecting an additional resistor in series with the coil.
2. By using constant current supply.
3. By using the known chopper supply.
4. By bilateral supply to stator coils.

Also, the torque-speed characteristic and efficiency of the drive can be improved if a constant current switched mode supply is used. There is good reason to run a stepping motor at a supply voltage above that needed to push the maximum rated current through the motor windings. Running a motor at higher voltages leads to a faster rise in the current through the windings when they are turned on, and this, in turn, leads to a higher cutoff speed for the motor and higher torques at speeds above the cutoff.

Microstepping, where the control system positions the motor rotor between half steps, as a result it requires external current limiting circuitry. For example, to position the rotor 1/4 of the way from one step to another, it might be necessary to run one motor winding at full current while the other is run at approximately 1/3 of that current. This paper however, discusses various methods for reducing the current rise through the windings of a stepping motor, using choppers and other switching regulators.

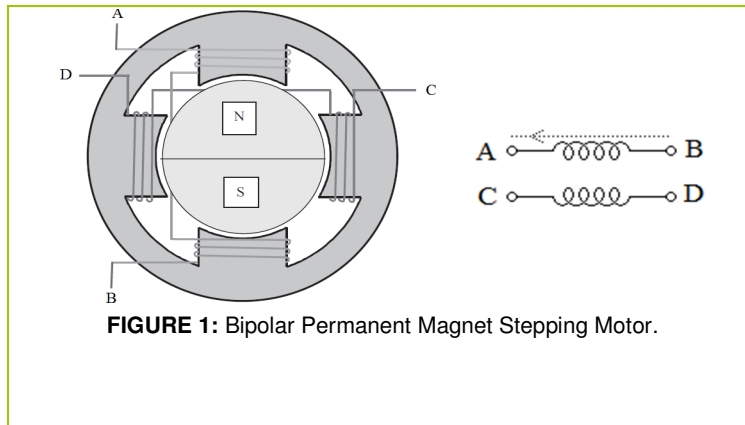

FIGURE 1: Bipolar Permanent Magnet Stepping Motor.

As a result it requires external current limiting circuitry. For example, to position the rotor 1/4 of the way from one step to another, it might be necessary to run one motor winding at full current while the other is run at approximately 1/3 of that current. This paper however, discusses various methods for reducing the current rise through the windings of a stepping motor, using choppers and other switching regulators.

2. BIPOLAR PERMANENT MAGNET STEPPING MOTOR

Bipolar permanent magnet and hybrid motors are constructed with exactly the same mechanism as is used on bipolar motors, but the two windings are wired more simply, with no center taps. Thus, the motor itself is simpler but the drive circuitry needed to reverse the polarity of each pair of motor poles appear more complex. Figure 1 shows how such a motor is wired, while the motor cross section shown here is exactly the same as the cross section in bipolar motors.

A bipolar PM stepper motor has a single winding for each phase and the current must be reversed to reverse the stator field. Bipolar motors, however, have two windings wound in opposite directions for each phase so that the field can be reversed with a single polarity drive. The stepper motor torque can be increased only by increasing the number of turns or by increasing current. If the current is allowed to increase indefinitely, there is a risk of saturation of the iron core of the stator. Furthermore, a more important factor is that the winding temperature will rise if the current is increased. This shows one advantage of the bipolar circuit, which, compared to the bipolar systems has only half of the copper resistance because of the double cross section of the wire. The winding current however, may be increased by a factor of 1.4 and this produces a direct proportional effect on the torque. At the power loss limit bipolar motors thus deliver about 40% more torque than bipolar motors built on the same frames. If higher torque is not required, the motor size may be reduced for bipolar motors.

2.1. Mathematical Model and Equivalent Circuit

The equivalent circuits of the electrical section of the bipolar stepper motor have been built with the supposition that the magnetic circuit is linear (no saturation) and the mutual inductance between phases is negligible. The mechanical section is represented by a state-space model based on inertia moment and viscous friction coefficient. For a permanent-magnet (PM) or hybrid stepper motor, the equivalent circuit for one

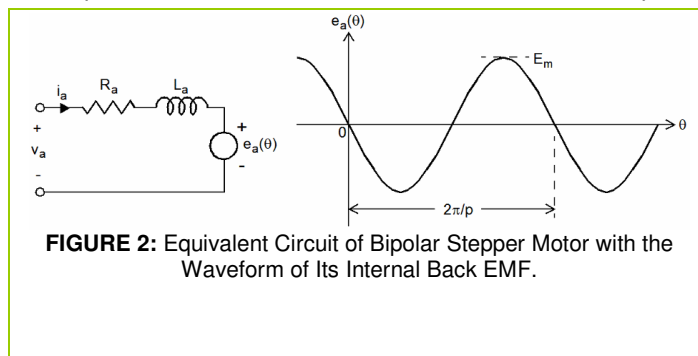

FIGURE 2: Equivalent Circuit of Bipolar Stepper Motor with the Waveform of Its Internal Back EMF.

phase is shown in Figure (2).

In this model, R_a and L_a represent respectively the resistance and inductance of A-phase winding. Due to the large value of the air gap introduced by the magnets, the winding inductance of the permanent-magnet or hybrid stepper motor can be considered to be

independent of the rotor position. The voltage source $e_a(\theta)$ represents the motor back EMF (electromotive force) which is a sinusoidal function of the rotor position:

$$e_a(\theta) = -p\psi_m \sin(p\theta) \frac{d\theta}{dt} \quad (1)$$

where p is the number of pole pairs and ψ_m is the motor maximum magnetic flux.

Note that at the reference position ($\theta = 0$), the North pole on the rotor is fully aligned with A-axis pole, (as shown in Figure (1)), so that the A-phase back EMF is then zero.

The electromagnetic torque produced by a two-phase PM or hybrid stepper motor is equal to the sum of the torque resulting from the interaction of the phase currents and magnetic fluxes created by the magnets and the detent torque, which results from the saliency of the rotor, hence;

$$T_e = -p\psi_m i_a \sin(p\theta) - p\psi_m i_b \sin(p\theta - \pi/2) - T_{dm} \sin(2p\theta) \quad (2)$$

Where i_a and i_b are the currents in windings A and B.

Also,

$$J \frac{d^2\theta}{dt^2} + D \frac{d\theta}{dt} + N_r \psi_m i_a \sin(N_r \theta) + N_r \psi_m i_b \sin(N_r(\theta - \lambda)) + C \operatorname{sign}\left(\frac{d\theta}{dt}\right) + T_L = 0 \quad (3)$$

Where J denotes the moment of rotor inertia ($Kg.m^2$), D denotes the viscous damping coefficient ($N.m.s.rad^{-1}$), C represents the coulomb friction coefficient, and T_L is the load torque [4, 6].

The mechanical part of the permanent magnet stepper motor model may be expressed by an equation derived from equations (1), (2) and (3).

The electrical part of a permanent magnet stepper motor model is described by voltage equations for the stator windings:

$$V - r i_a - L \frac{di_a}{dt} - M \frac{di_b}{dt} + \frac{d}{dt} (\psi_m \cos(N_r \theta)) = 0 \quad (4)$$

$$V - r i_b - L \frac{di_b}{dt} - M \frac{di_a}{dt} + \frac{d}{dt} (\psi_m \cos(N_r(\theta - \lambda))) = 0 \quad (5)$$

Where V is the dc terminal voltage supplied to the stator windings, L represents the self-inductance of each stator phase, M denotes the mutual inductance between phases and r is stator circuit resistance. Thus, the complete model of the permanent magnet stepping motor consists of the rotor dynamic equation (3) and differential equations for current; equations (4) and (5). Those equations are nonlinear differential equations. Since it is very difficult to deal with nonlinear differential equations analytically, linearization is needed. Linearization is made with aid of a new variable $\delta\theta$, that represents the deviation of the angle from the equilibrium position. The deviation is a function of time t and it is very small in magnitude.

When the rotor oscillates about its equilibrium position, the currents in both motor windings will deviate from the stationary value I_o by δi_a and δi_b and the angular rotor position can be expressed by:

$$\theta = \frac{\lambda}{2} + \delta\theta \quad (6)$$

The current in both windings can also be expressed as follows:

$$i_a = I_s + \delta i_a \tag{7}$$

$$i_b = I_s + \delta i_b \tag{8}$$

Then the nonlinearities expressed by sin and cosine functions in equations (3), (4) and (5) will be approximated with knowledge of trigonometric identities and when $Nr\delta\theta$ is small angle: $\cos(Nr\delta\theta) = 1$ and $\sin(Nr\delta\theta) = Nr\delta\theta$.

3. TORQUE SPEED CHARACTERISTIC OF PM STEPPING MOTOR

An important issue in designing high-speed stepping motor controllers is the effect of inductance of the motor windings. As with the torque versus angular position information, this is often poorly documented and indeed, for variable reluctance stepping motors, it is not a constant. The inductance of the motor winding determines the rise and fall time of the current through the windings. While it is hoped for a square-wave plot of current versus time, the inductance forces an exponential, as depicted in Figure (3). The details of the current-versus-time function through each winding depend as much on the drive circuitry as on the motor. The rise time is determined by the drive voltage and drive circuitry, while the fall time depends on the circuitry used to dissipate the stored energy in the motor winding.

At low stepping rates, the rise and fall times of the current through the motor windings has little effect on the motor's performance, but at higher speeds, the effect of the inductance of

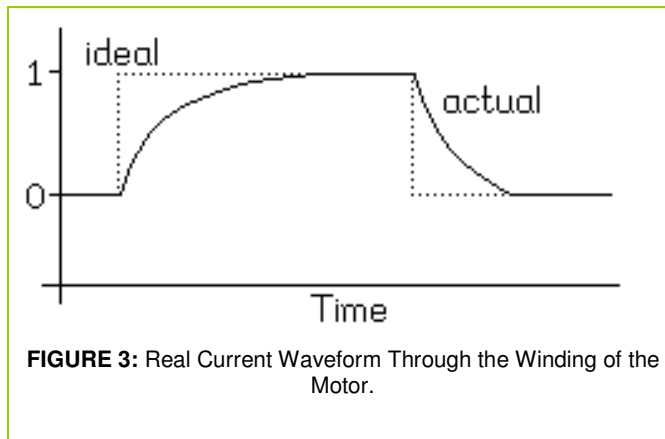

the motor windings is to reduce the available torque, as illustrated in Figure (4).

The motor's *maximum speed* is defined as the speed at which the available torque falls to zero. Measuring maximum speed can be difficult when there are resonance problems, because these cause the torque to drop to zero prematurely. When the motor is operating below

its cutoff speed, the rise and fall times of the current through the motor windings occupy an insignificant fraction of each step, while at the cutoff speed, the step duration is comparable to the sum of the rise and fall times. Note that a sharp cutoff is rare, and therefore, statements of a motor's cutoff speed are approximate.

The details of the torque versus speed relationship depend on the details of the rise and fall times in the motor windings, and these depend on the motor control system as well as the motor. Therefore, the cutoff speed and maximum speed for any particular motor depend, in part, on the control system! The torque versus speed curves published in motor data sheets occasionally come with documentation of the motor controller used to obtain that curve.

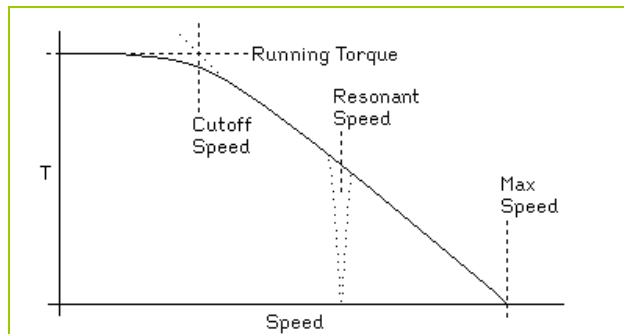

FIGURE 4: Torque Speed Characteristic of a pm Stepping Motor.

Similarly, the resonant speed depends on the moment of inertia of the entire rotating system, not just the motor rotor, and the extent to which the torque drops at resonance depends on the presence of mechanical damping and on the nature of the control system. A study of torque versus speed curves show very clear resonances without documenting the moment of inertia of the hardware that may have been attached to the motor shaft in order to make torque measurements.

The torque versus speed curve shown in Figure (3) is typical of control systems. More complex control systems sometimes introduce electronic resonances that act to increase the available torque above the motor's low-speed torque. A common result of this is a peak in the available torque near the cutoff speed.

The torque versus speed curve shown in Figure (3) is typical of control systems. More complex control systems sometimes introduce electronic resonances that act to increase the available torque above the motor's low-speed torque. A common result of this is a peak in the available torque near the cutoff speed.

4. BASIC CONTROL CIRCUITS

The associated drive circuitry for stepping motors are centered on a single issue, switching the current in each motor winding ON and OFF, and controlling its direction. The circuitry discussed in this section is connected directly to the motor windings and the motor power supply, and this circuitry is controlled by a digital system that determines when the switches are turned ON or OFF.

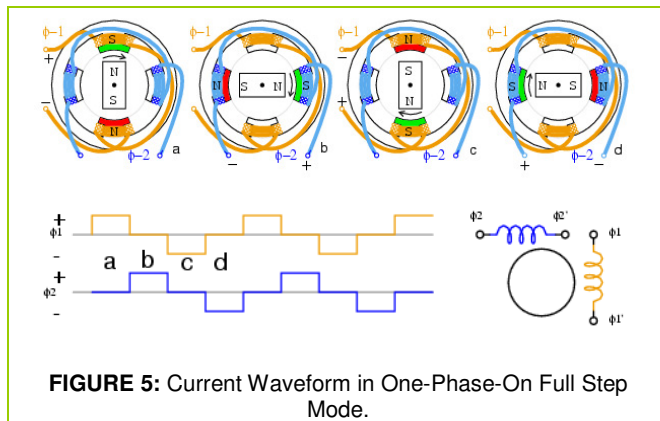

FIGURE 5: Current Waveform in One-Phase-On Full Step Mode.

This paper initially only covers theoretically the most elementary control circuitry for motor power supply provides a drive voltage no greater than the motor's rated voltage, and this significantly limits the motor performance. Furthermore, in this research on current limited drive circuitry, covers practical high-performance drive circuits.

bipolar stepping motors. All of these circuits assume that the

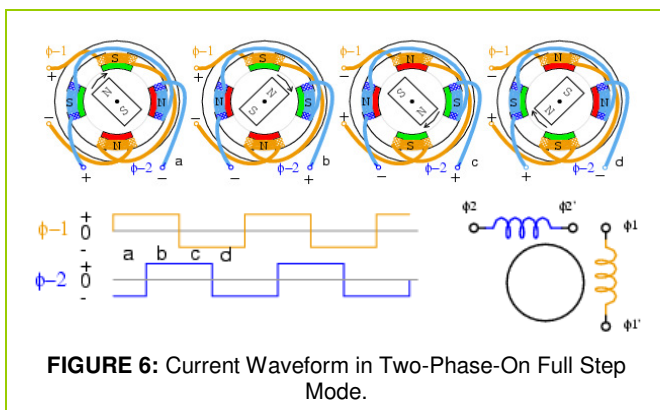
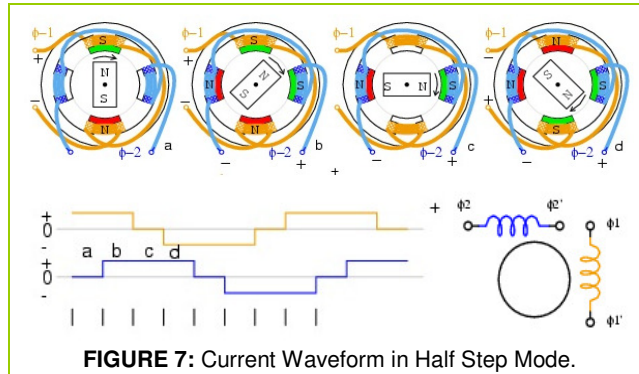

FIGURE 6: Current Waveform in Two-Phase-On Full Step Mode.

A two phase bipolar motor has two stator windings and there are three possible drive sequences. With reference to Figure (1) the first one is to

energize the winding in the sequence AB-CD-BA-DC. AB means current should flow from terminal A to B. BA means current flows from terminal B to A. This sequence is known as "One phase on full step", or wave drive mode. At this mode only one phase is energized at any time. While simple, this does not produce as much torque as the other drive techniques. This sequence is illustrated in Figure (5).



The second method is to energize both phases together so that the rotor is always aligned between two pole positions. This is called "two-phase-on full step". This mode provides more torque than wave drive because both coils are energized at the same time. This attracts the rotor poles midway between the two field poles. This mode is the normal drive sequence for a bipolar motor and gives the highest

torque. The sequence is pictorially shown in Figure (6).

The third sequence is to energize one phase, then two and then one phase again followed by two phase and so on. In this mode the motor moves in half step increments. This sequence is called as half step mode. In two-phase full step mode the step angle is 90° and in half step mode the step angle is 45°. However, Two phase or two pole motors are not used. Real motors have multiple poles to reduce the step angles to a few degrees but the number of windings and the drive sequences are unchanged. The half step drive sequence is shown in Figure (7).

5. BIPOLAR MOTOR DRIVES

The permanent magnet stepping motor drive system in general should fulfill the following requirements:

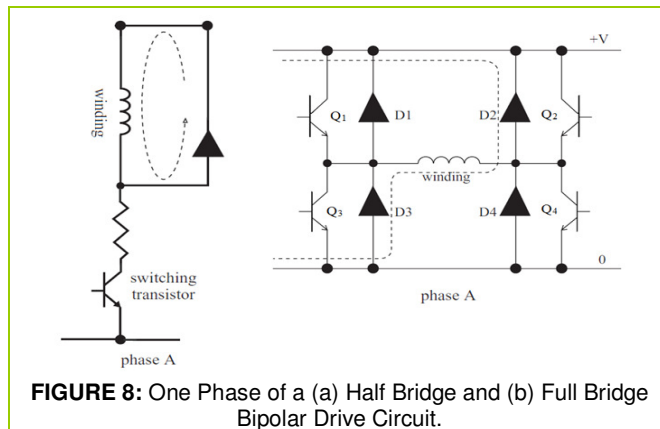

- a) Have adequate power capacity to accelerate the motor under maximum load.
- b) Provide fast switching control of each phase winding.
- c) Facility to determine the required direction of rotation.
- d) Facility to sequence the winding directly.

e) Bipolar drives are used for stepping motors having single winding per phase. Things are more complex for bipolar pm stepping motors because these have no center taps on the

windings. Therefore, to reverse the direction of the field produced by a motor winding, it is required to reverse the current through the winding.

Bipolar drive is usually obtained by two methods such as half bridge with two polarity supply source and full bridge with single polarity supply. These are shown in Figure (8). The four switching transistors in the bridge require separate base drives to amplify the two (positive and negative) phase control signals. In the case of the 'upper' transistors (T1 and T2) the base drive must be referred to the positive supply rail, which may be at a variable potential. For this reason the phase control signals to these upper base drives are often transmitted via a stage of optical isolation. A bridge of four diodes, connected in reverse parallel with the switching transistors, provides the path for freewheeling currents.

In the half bridge circuit the phase winding is excited whenever its switching transistor is saturated by a sufficiently high base current. The switching transistor and the diode are driven alternately in order to pass bidirectional current through each phase of the stepper motor.

6. PRACTICAL IMPLEMENTATION AND MODELING OF BIPOLAR STEPPING MOTOR

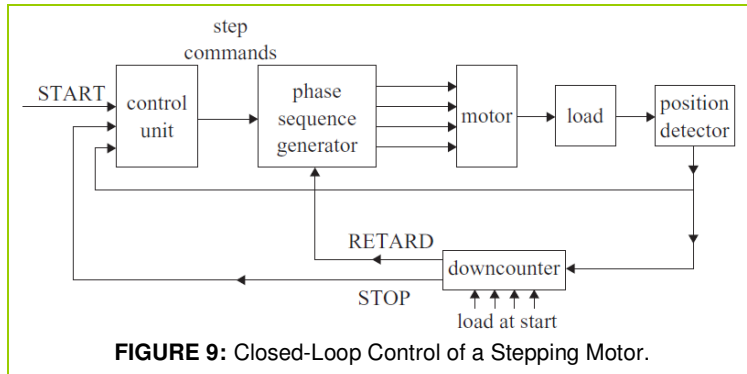

FIGURE 9: Closed-Loop Control of a Stepping Motor.

Originally, stepping motors were designed to provide precise position and velocity control within a fixed number of steps using open loop control. In this research, the stepping motor mathematical model is simulated using MATLAB for analysis and for studying its

response in different environments. The following motor parameters were taken from the motor specification (Table I) and are constant throughout the simulation.

In a closed-loop stepping motor system the rotor position is detected and fed back to the control unit. Each step command is issued only when the motor has responded satisfactorily to the previous command and so there is no possibility of the motor losing synchronism.

A schematic closed-loop control is shown in Figure (9). Initially the system is stationary with one or more phases excited. The target position is loaded into the downcounter and a pulsed START signal is applied to the control unit, which immediately passes a step command to the phase sequence generator. Consequently, there is a change in excitation and the motor starts to accelerate at a rate dictated by the load parameters.

Motor Parameters	Symbol	Value	Units
Rotor Load Inertia	J	$2.02 \cdot 10^{(-6)}$	N-m-S ² /rad
Viscous Friction	B	$1 \cdot 10^{(-3)}$	N-m-S ² /rad
Self Inductance of Winding	L	0.005	Henry
Resistance in Phase Winding	R	2.5	Ohm
Number of rotor teeth	N	100	
Motor Torque Constant	K_m	0.05	V-S/rad

TABLE I: Motor Simulation Specification.

The following mechanical model shows a 4-phase step motor. Whose electrical part is modeled by 4 electrical circuits in parallel connection.

There are different ways to model the mechanical part of the motor in Simpler as

shown in figure (10). Here an electrical circuit is used to describe its mechanical behavior.

It can be modeled in the form of a block diagram as well. The control signal of the step motor is produced by 3-state machines. One for direction control, such as the required step length and moving direction. The others for generating pulse signals, which depends on the moving direction. By using static transistor model in Simpler, the logic control signal can be connected directly to the transistor as a switch signal. A static transistor model is good enough to simulate the controlled behavior of the step motor in this particular case.

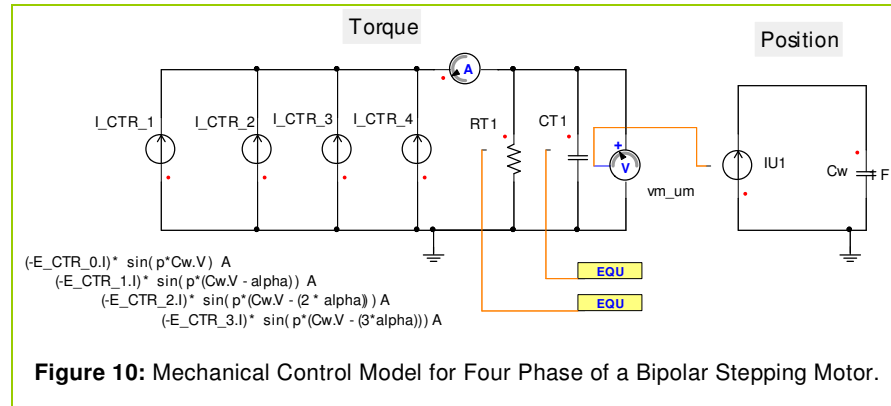

7. SIMULATION RESULTS

An application of the chopper controller to a permanent magnet four phase stepping motor has been presented. It was proved that the robustness of stability and performance (disturbance elimination, following error and desired value tracking) were fulfilled by applying such controller with the presence of system parameters uncertainty. Also it was clear that the obtained controller was simple, robust and low order. The main objectives of the controller were verified by simulation in Simpler 7.

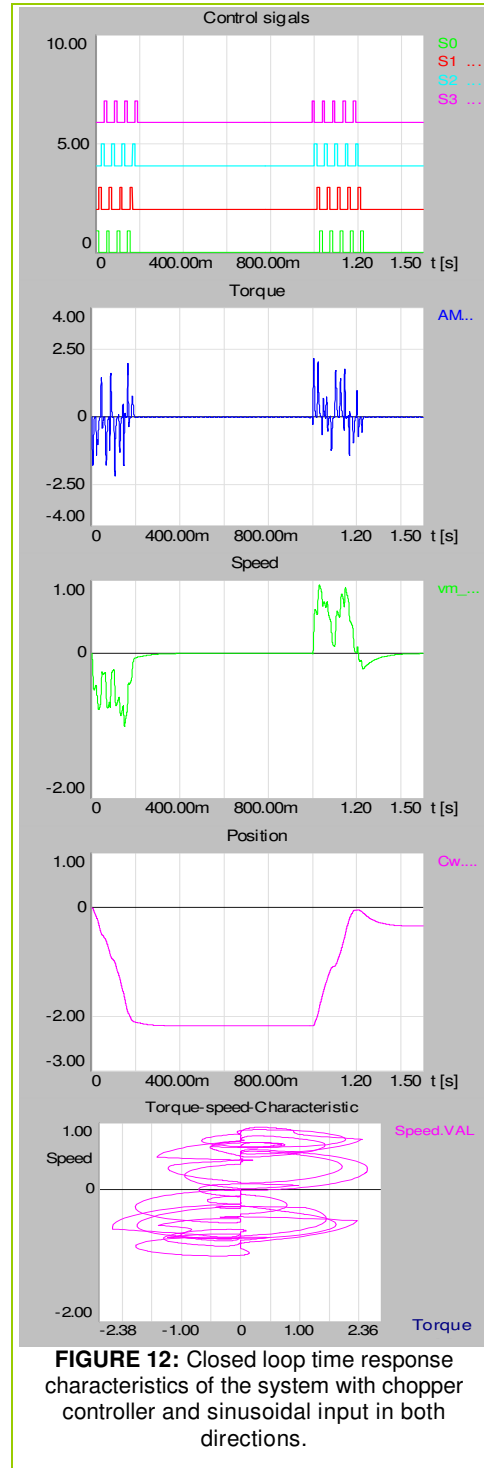
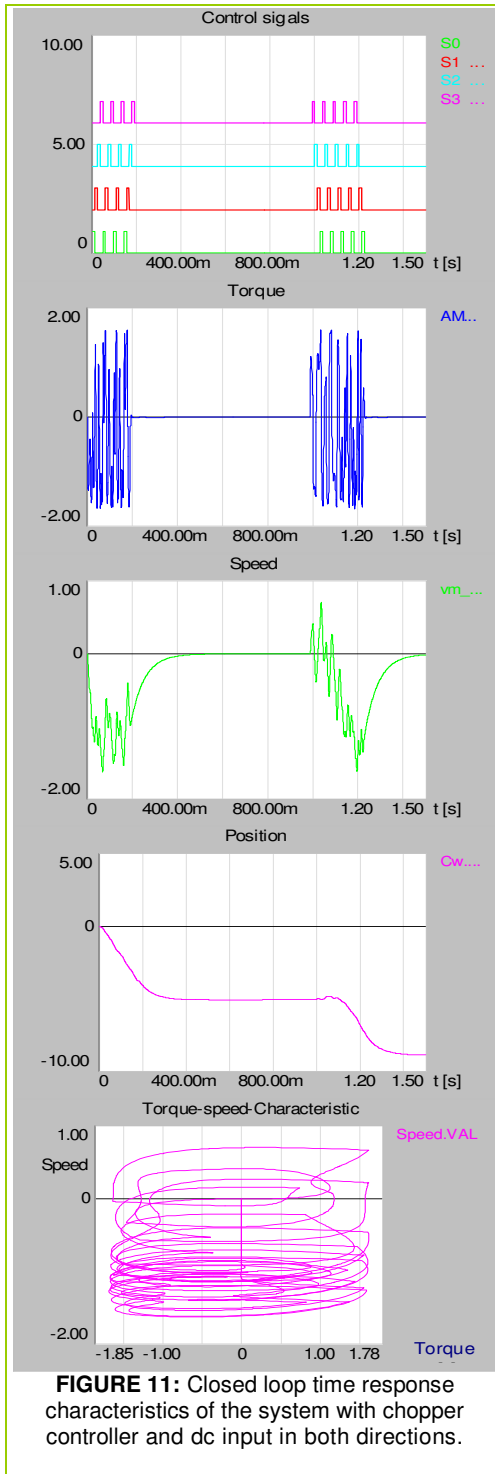

Figures (11) shows the plot of the motor speed, torque, position and control signals with 12 poles and dc input voltage for both direction-motor. Figure (12) shows the plot of the motor speed, torque, position and control signals with sinusoidal input. The same plots are show in Figure (13) for a square wave input.

When the reliability of the chopper control method is compared to other known techniques, chopper control begins to look very attractive, because it eliminates many of the problems

associated with stepper motor operation (mechanical resonance, intolerance of load changes, commutation time of current between phases).

The results illustrate the robust stability and system disturbance rejection. An improved response with good reference tracking was satisfied after the adding of the prefilter at the output as shown in figures (12) and (13).

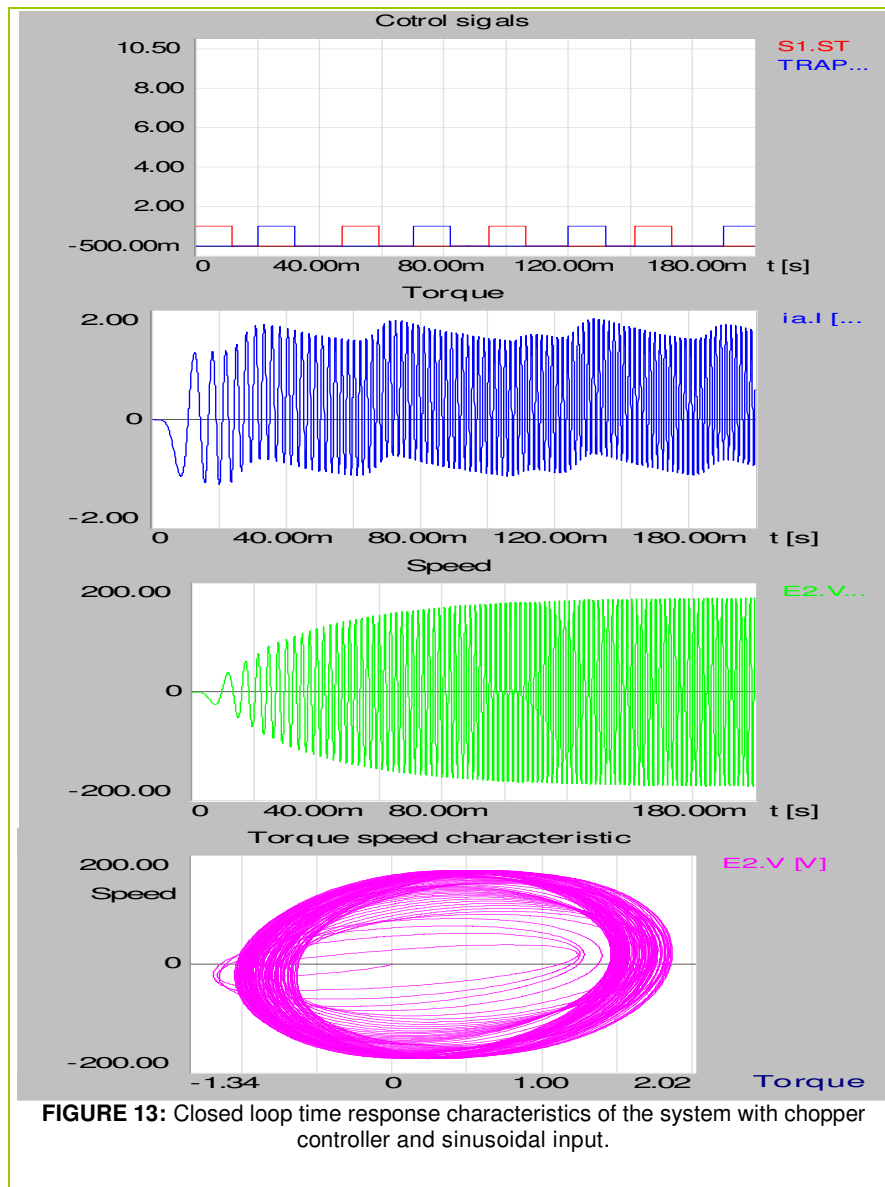

8. CONCLUSION

This paper describes application examples of modern control and drive circuits. It shows that performance and efficiency of bipolar stepping motors may be remarkably increased without any excessive expense increase, as discussed in previous researches. Working in limit areas, where improved electronics with optimized drive sequences allow the use of less expensive motors, it is even possible to obtain a cost reduction.

The following explains the basics of stepping motor drive and assists in selecting the most suitable drive technique. The dynamic response of a stepping motor depends on the behavior

of its rotor which is usually influenced by inertia, frictional forces and holding torque which are significantly dependent on the motor current.

A natural limit against any current increase by using additional power electronic devices and very high power supply as in the full bridge control method is the danger of saturating the iron core and increasing the maximum temperature of the motor, due to the power loss in the stator windings. The winding current is chopped and limited within a certain limit and this produces a direct proportional and positive effect on the torque. At the power loss limit stepping motors with anti-parallel series four phase chopper control may deliver more torque than stepping motor with other drive circuits.

Furthermore, if a higher torque is not required, then either reduce the motor size or the power loss by utilizing the chopper control method. It also gives with a variable output voltage, the possibility of varying the motor speed by varying its terminal voltage.

An application of the chopper controller to a permanent magnet four phase stepping motor has been presented. It is shown that the robust stability and performance (disturbance rejection, reference tracking) were satisfied with the presence of system parameters uncertainty. Also it is clear that the obtained controller is simple, robust and low order. The main objectives of the controller are verified by simulation. The simulation results obtained also show that chopper control used in this paper results in the same good performance and dynamic characteristics of bipolar PM stepping motor exactly as the HB Bcontrol technique, fuzzy control technique, neural network control, active disturbance rejection control, or other optimized control techniques used in [2-10].

9. REFERENCES

- [1] R.W. De Doncker, D. W. Novonty. "The Universal Field Oriented Controller," IEEE Trans. Ind. Applicat., vol. IA-30, No 1, 1994, pp. 92-100.
- [2] D. W. Jones: "Control of stepping motors", University of Iowa, Dept. of Computer Science, <http://www.cs.uiowa.edu/~jones/step/>.
- [3] P. C. Sen: "Modern Power Electronics". Published by S. Chand & Company LTD. New Delhi, 2004.
- [4] W. Theodore: "Electrical machines, drives, and power systems", sixth edition. Published by Pearson education international, New Jersey 07458, 2006.
- [5] W. D. Harries and J. H. Lang: "A simple motion estimation for variable reluctance motors, IEEE Trans. Ind. Appl., pp 237-243, March 1990.
- [6] M. Hajatipour, M. Farrokhi, "Adaptive intelligent speed control of switched reluctance motors with torque ripple reduction", Energy Conversion and Management, Vol. 49, No. 5, pp. 1028-1038, 2008.
- [7] E. Karakas, S. Vardarbasi, "Speed control of SR motor by self-tuning fuzzy PI controller with artificial neural network" in S^cadhan^a Academy Proceedings in Engineering Sciences, Vol. 32, No. 5, pp. 587-596, 2007.
- [8] V. I. Utkin, H. C. Chang, "Sliding Mode Control on Electro-Mechanical Systems", Mathematical Problems in Engineering, Vol. 5, No. (4-5), pp. 451-473, 2002.
- [9] D. W. Jones: "Control of Stepper Motors". Sections 5.2.10, 10.8, 10.9 and 10.10 of the *Handbook of Small Electric Motors* edited by W. H. Yeadon and A. W. Yeadon, McGraw-Hill, 2001. <http://www.cs.uiowa.edu/~jones/step>
- [10] R. Krishnan, "Switched Reluctance Motor Drives: Modeling, Simulation, Analysis, Design, and Applications", Industrial Electronic Series, CRC Press LLC, 2001.

- [11] D. Carrica, M. A. Funes and S. A. Gonzalea: "Novel Stepper Motor Controller Based on FPGA Hardware Implementation". *IEEE/ASME Trans. Mechatronics*, vol. 8, No. 1, pp.120-124, March 2003.
- [12] D. Austin: "Generate stepper-motor speed profiles in real time". Article in *Embedded Systems Programming*, January 2005.
<http://www.embedded.com/showArticle.jhtml?articleID=56800129>
- [13] **Morar, A.:** "Sisteme electronice de comandă și alimentare a motoarelor pas cu pas implementate pe calculatoare personale (Electronic systems for stepping motor control implemented on personal computers)". *Teză de doctorat*, Universitatea Tehnică din Cluj-Napoca, 2001.
- [14] P. Crnosija, B. Kuzmanovic, and S. Ajdukovic, "Microcomputer implementation of optimal algorithms for closed-loop control of hybrid stepper motor drives," *IEEE Trans. Ind. Electron.*, vol. 47, no. 6, pp. 1319–1325, Dec. 2000.
- [15] W. D. Chen, K. L. Yung, and K. W. Cheng, "Profile tracking performance of a low ripple hybrid stepping motor servo drive," *Proc. Inst. Elect.Eng.—Control Theory Appl.*, vol. 150, no. 1, pp. 69–76, Jan. 2003.
- [16] W. D. Chen, K. L. Yung, and K. W. Cheng, "A learning scheme for lowspeed precision tracking control of hybrid stepping motors," *IEEE/ASME Trans. Mechatronics*, vol. 11, no. 3, pp. 362–365, Jun. 2006.
- [17] S.-M. Yang and E.-L. Kuo, "Damping a hybrid stepping motor with estimated position and velocity," *IEEE Trans. Power Electron.*, vol. 18, no. 3, pp. 880–887, May 2003.
- [18] B. K. Bose, "Neural network applications in power electronics and motor drives—An introduction and perspective," *IEEE Trans. Ind. Electron.*, vol. 54, no. 1, pp. 14–33, Feb. 2007.