

# Real Time Implementation of Adaptive Beam former for Phased Array Radar over DSP Kit

**Muhammad Amir Shafiq**

*Faculty of Electronics Engineering  
GIKI,  
Topi, Pakistan*

*amirshafiq@gmail.com*

**Saqib Ejaz**

*Faculty of Electronics Engineering  
GIKI,  
Topi, Pakistan*

*saqibejaz@gmail.com*

**Nisar Ahmed**

*Faculty of Electronics Engineering  
GIKI,  
Topi, Pakistan*

*nisarahmed@giki.edu.pk*

---

## Abstract

Mechanical positioners, rotating antennas and large size of early generation radars limited the capability of the radar system to track laterally accelerating targets. Electronic Scanning Array (ESA) such as used in Phased Array Radar (PAR) overcame these limitations by providing beam agility, good response time, variable scan rates and efficient use of energy. Early PAR systems used analog phase shifting schemes that caused variations and component failures resulting in overall degradation of radar performance. With the advent of new technology and high performance embedded systems, digital beamforming has become powerful enough to perform massive operations required for real time digital beamforming. MATLAB simulation of adaptive beamformer is presented in this paper. Real time implementation of adaptive beamformer over DSP kit (TMS320C6713) was also carried out and results were compared with MATLAB simulations. GUI was also made in MATLAB for viewing results of real time implementation via real time data exchange. Developed system can be used in digital beamforming PAR provided array signals are routed to DSP kit through FPGA interfaced to high speed ADC's.

**Keywords:** Digital Beamforming, Phased Array Radar, NLMS, Adaptive Beamformer, DSP kit TMS320C6713.

---

## 1. INTRODUCTION

Phased Array Radar (PAR) has been used largely in communication systems and attracted the interest of many researchers from last few decades. PAR technology is better than conventional mechanically steered radars in terms of coverage, response time, scan rate, acquisition and simultaneous tracking of multiple targets. Their capability to change radiation pattern electronically, multi-beam capacity and high spatial resolution has made them attractive for mobile communication applications as well [1].

PAR can generally be categorized as two types: Analog PAR and digital PAR. Adaptive beamforming is integral part of digital PAR system. Digital beamforming offers advantages in terms of power consumption, flexibility, and accuracy as compared to analog beamforming techniques. In general, digital systems tend to consume less power in computation operations and have programmable interface adding versatility to the system. Also digital systems provide

adaptive pattern nulling, super resolution, array element pattern correction, self calibration, and radar power and time management [2].

Digital beamforming offers great deal of flexibility without degrading Signal to Noise Ratio (SNR). Adaptive beamforming further improves the functionality of system by suppressing any interference signals and offering high jamming resistance [3-4]. Adaptive beamforming can be used to shape the radiation pattern for both reception and transmission of signal. Adaptive beamforming optimize the beamformer response so that output contains minimal contribution due to noise and interferers [5]. Design of transmitter and receiver of digital beam former is presented in [6]. Simulations are carried out using 4-element linear array to demonstrate control of radiation pattern of antenna. L-band signal processor using Field Programmable Gate Arrays (FPGA) for digital beamforming antenna is presented in [7]. Hardware implementation in [7] offers selection and synthesis of multiple beams formed using 16 element antenna.

In this paper, simulation and real time implementation of Adaptive Beamformer (ABF) is presented. Implementation is based on the far-field plane wave incident on a 1x4 Uniform Linear Array (ULA). Rest of paper is organized as follows. Problem statement is given in Section 2. Theory of adaptive beamformer is presented in Section 3. Introduction to DSP kit and real time implementation is given in Section 4. Experimental setup and results are also discussed in Section 4. Finally conclusion is given in Section 5.

## 2. PROBLEM STATEMENT

Consider a point source P which is broadcasting in all directions shown in Fig. 1. Let  $\theta$  be an angle that source subtends at ULA. ULA consists of four antennas spaced at  $0.5 \lambda$

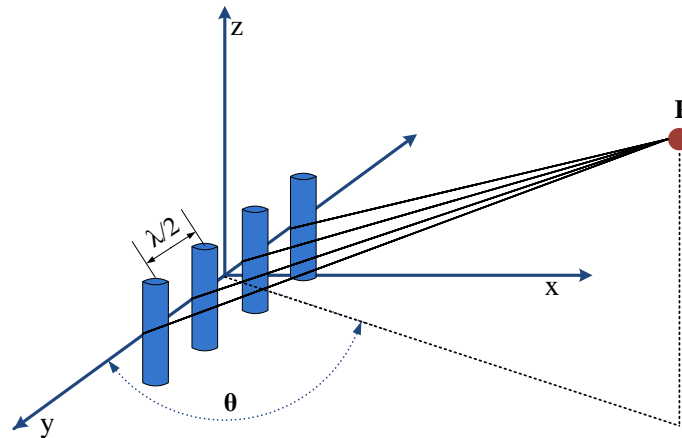

FIGURE 1: 1x4 Uniform Linear Array.

The incident plane wave on ULA is given by (1) [8].

$$\begin{aligned} e(t, p_n) &= x(t - \tau_n) \cos(\omega_{RF}(t - \tau_n)) \\ &\approx x(t) \cos(\omega_{RF}t - \theta_n) \end{aligned} \quad (1)$$

where  $\theta_n = \omega_{RF} \tau_n$ ,  $\omega_{RF}$  is a radio frequency and  $\tau_n$  is a time delay due to the nth antenna element. This incident plane wave as received by the antennas of the ULA is modeled and simulated in MATLAB. Our aim is to design a beamformer processor that will steer the main beam of ULA to our desired angle. Developed adaptive beamformer processor will be used in PAR. Simplified block diagram of PAR is shown in Fig. 2.

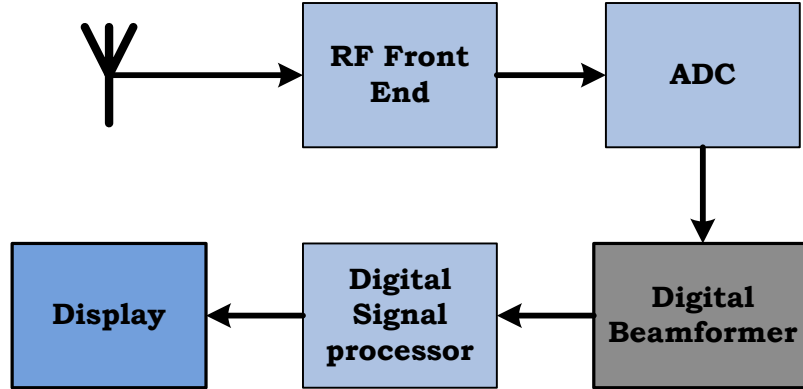

FIGURE 2: Simplified Phased Array Radar Block Diagram.

### 3. ADAPTIVE BEAMFORMER

Beamforming is combination of radio signal from a set of non-directional antennas to simulate one antenna with directional properties. Formed beam can be steered electronically using phase shifters. Phase shifters can be adjusted to enhance or suppress reception of signal from certain area. In this way, beamforming can also be used for direction finding applications as well [9].

In digital beamforming, phase shifting operation, amplitude scaling for each antenna element and summation for receiving are done digitally [10]. General purpose Digital Signal Processor (DSP) or dedicated beamforming chips are used for digital beamforming. Digital beamforming apply different weights to adjust amplitude and phase of digital signal to form the beam in desired direction. Amplitude and direction of beams are controlled by digital signal processor. Adaptive beamforming not only steer main beam to desired direction but can also be used for steering nulls in direction of jammer or interferer. Weights adapt to changes in location of interfering signal while maintaining response towards the desired signal [11]. In adaptive beamformer, complex weights are adapted continuously until desired results are obtained. In this way adaptive beamformer also optimize the array pattern by controlling the weights of digital signal [3].

Multiple independent beams can be formed and steered in all direction using digital beamforming processor [12]. Advantages of adaptive beamforming include improved dynamic range, controlling of multiple beams, better and faster control of amplitude and phase [12]. Advanced signal processing algorithms are used to locate and track the desired and interfering signals. Adaptive system then dynamically minimizes interference signal and maximize desired signal reception. PAR uses beam steering only, however beam steering and nulling both are used in adaptive beamforming [13]. A generic adaptive beamformer is shown in Fig. 3.

The output  $y(k)$  at time instant  $k$  is given by a linear combination of the data at the  $M$  sensors multiplied by weights vector. In vector form, it is written as (2)

$$y(k) = \sum_{i=0}^{M-1} w_i^*(k)x_i(k) \tag{2}$$

where  $*$  represents complex conjugate. With adaptive beamformer system, we can point beam in any direction and manipulate beam shape to optimize system performance by changing the weights vector  $W$ .  $W$  is given by (3)

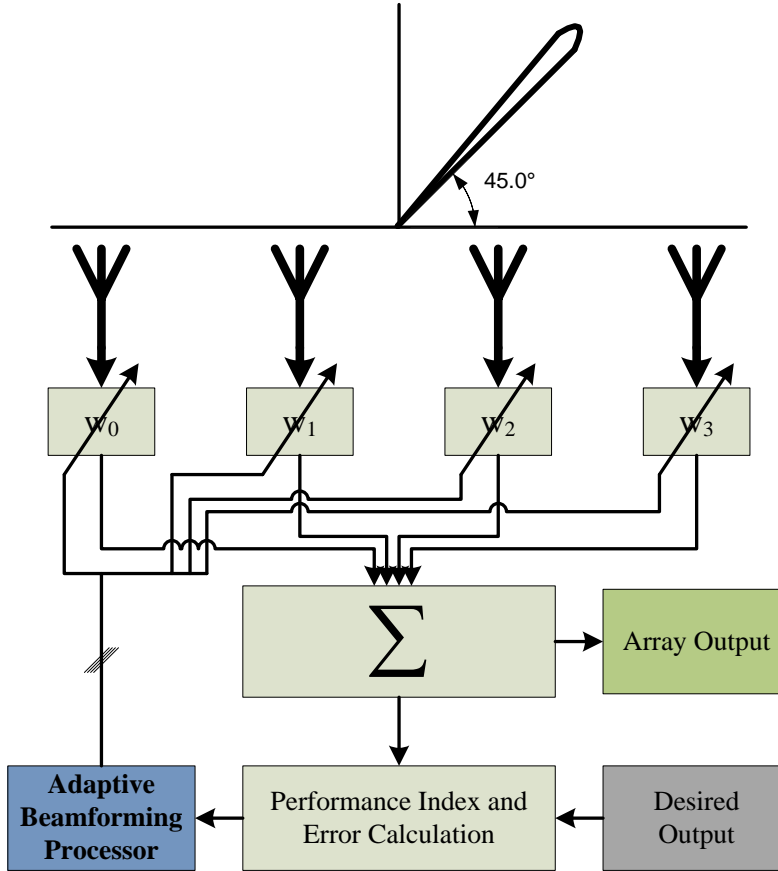

FIGURE 3: A Generic Adaptive Beamformer System.

$$W(k) = [w_0^*(k) \quad w_1^*(k) \quad \dots \quad w_{M-1}^*(k)] \quad (3)$$

Weight vector  $W$  is updated using adaptive algorithm. Weight vector  $W$  is chosen adaptively to give desired peaks and null in radiation pattern of antenna array. Choice of adaptive algorithm depends on speed, convergence and hardware complexity required. Most commonly used adaptive algorithms are Least Mean Square (LMS), Normalized Least Mean Square (NLMS) and Recursive Least Square (RLS) etc [14]. We have used NLMS for weight updation because it has faster convergence as compared to LMS and low Mean Square Error (MSE). Also computational complexity of NLMS is less than RLS.

### 3.1 NLMS

Adaptive complex weights  $w_i^*(k)$  are calculated using adaptive NLMS algorithm [14]. Output of adaptive beamformer is calculated based on moving average system i.e. output is approximated by an adaptive Finite Impulse Response (FIR) filter. Mathematically,

$$e_{beam}(k) \rightarrow 0 \text{ as } k \rightarrow \infty \quad (4)$$

Where  $e_{beam}(k)$  is error mismatch between desired beam and digital beamformer output. Weight update equation for NLMS is given by (5).

$$W(k+1) = W(k) + \mu e_{beam}(k) \frac{X(k+1)}{\varepsilon + X^T(k+1)X(k+1)} \quad (5)$$

Where  $\mu$  is learning rate,  $W(k)$  is weight vector,  $X(k)$  is input vector and  $\varepsilon$  is very small real number approximately equal to zero. These weights  $W(k) = w_i^*(k)$  are obtained adaptively by conforming the signal in accordance to the desired signal.

### 3.2 Simulation Results

Adaptive beamformer was simulated in MATLAB. Simulation results are shown in Fig. 4. If we want to form a beam at  $45^\circ$  then we input this angle as our desired angle to adaptive beamformer processor. NLMS adapts the weights and steer the beam to  $45^\circ$ . Radiation pattern at  $45^\circ$  desired angle is shown in Fig. 4.

Radiation Pattern of Adaptive Beamformer Output

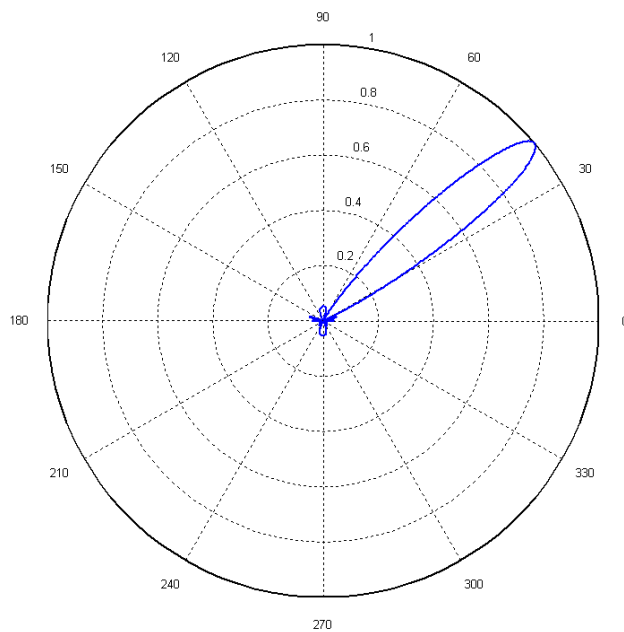

FIGURE 4: Radiation Pattern after Adaptive Beamforming.

NLMS adaptation error is shown in Fig. 5. It can be seen from the Fig. 5 that NLMS converges to desired angle quickly and  $e_{beam}(k) \rightarrow 0$  as  $k \rightarrow \infty$

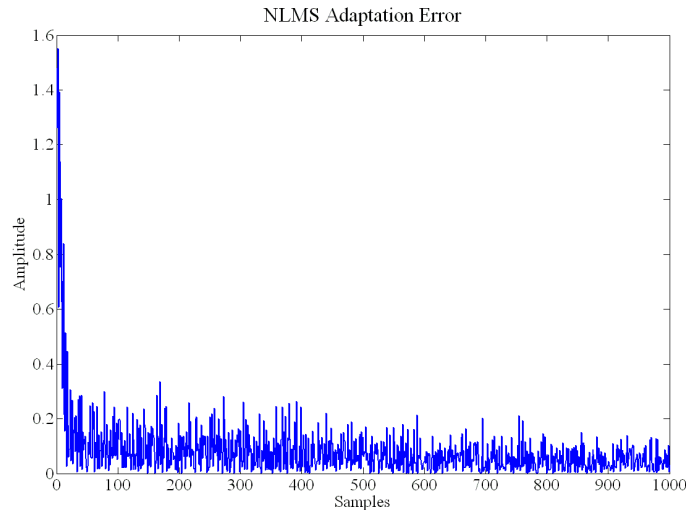

FIGURE 5: NLMS Adaptation Error.

### 3.3 Direction of Arrival Estimation

For direction finding application, weights of adaptive beamformer are changed slowly and beam is steered in space to find signal source. Angle at which quality of received signal maximizes radiation pattern of antenna array is direction of arrival of signal [9-10].

## 4. REAL TIME IMPLEMENTATION

DSP processors are concerned primarily with real-time signal processing [15]. Real-time processing requires the processing to keep pace with some external event, whereas non-real-time processing has no such timing constraint. For non-real time system, data can be recorded on PC and signal processing algorithms can be implemented offline. DSP based systems are less affected by environmental conditions. DSP processors enjoy the advantages of microprocessors [16]. They are easy to use, flexible, and economical. The DSP board which is used in this paper is TMS320C6713 which is the floating-point DSP generation in the TMS320C6000 DSP platform. The C6713 device is based on the high-performance, advanced Very Long Instruction Word (VLIW) architecture developed by Texas Instruments (TI), making this DSP an excellent choice for multichannel and multifunction applications [17]. Adaptive beamformer was successfully implemented on TMS320C6713 DSP kit. Block diagram of experimental setup is shown in Fig. 6.

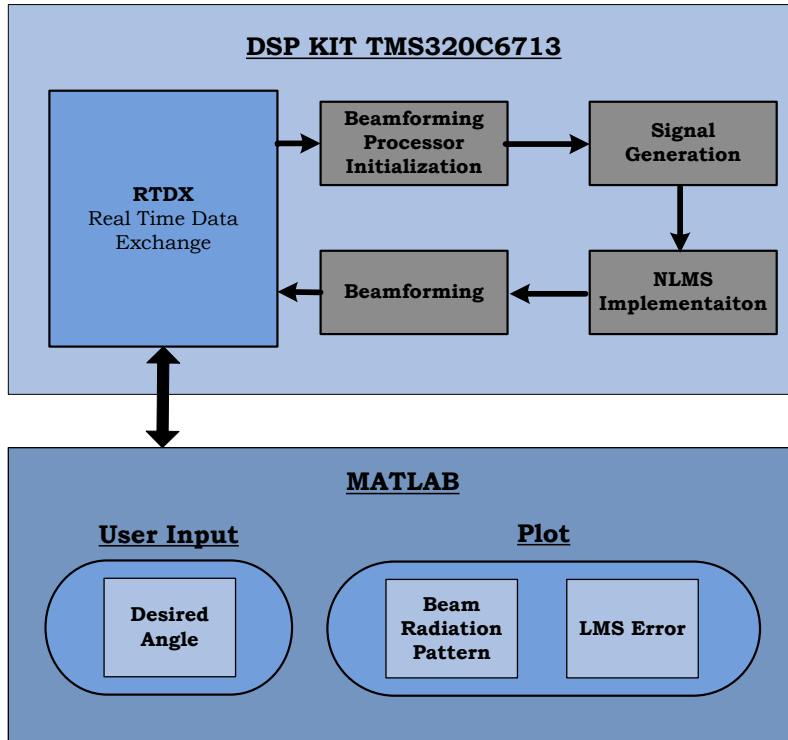

**FIGURE 6:** Block Diagram of Experimental Setup.

In current experimental setup synthetic data of ULA was generated over DSP kit and NLMS was used to adaptive beamforming. Only input required from user is desired angle to steer the main beam of ULA in that direction. In complete PAR system, desired angle will be controlled by signal processor for beam steering. MATLAB was used for designing Graphical User Interface (GUI) and plotting results of adaptive beamformer. Real Time Data Exchange (RTDX) was used for duplex data communication between MATLAB and code composer studio. User inputs the desired angle from GUI and after adaptive beamforming radiation pattern of ULA is plotted on GUI. NLMS adaptation error is also shown in GUI. GUI is shown in Fig. 7.

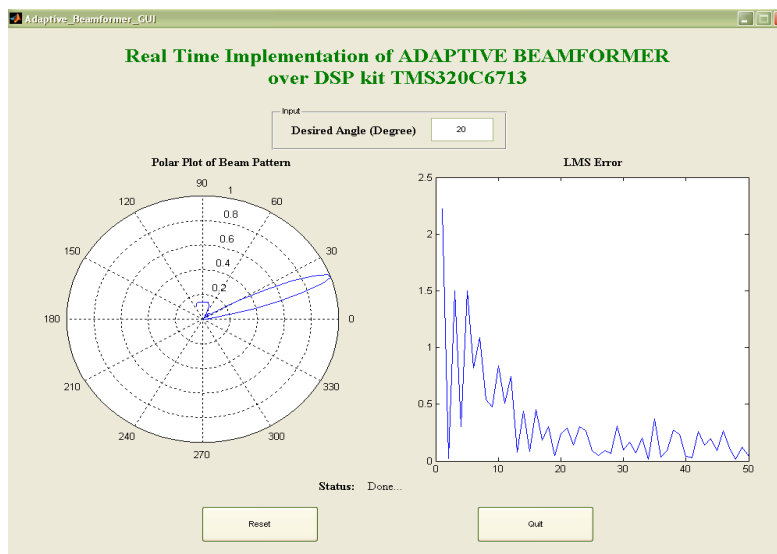

**FIGURE 7:** Graphical User Interface (GUI).

We also profiled the execution of adaptive beamforming code over DSP kit. Adaptation time for beamforming was found to be 3.31us. It can be seen from Fig. 4 and Fig. 7 that results of real time implementation accede with MATLAB simulation results which verify the effectiveness of DSP kit implementation. Hardware setup is shown in Fig. 8.

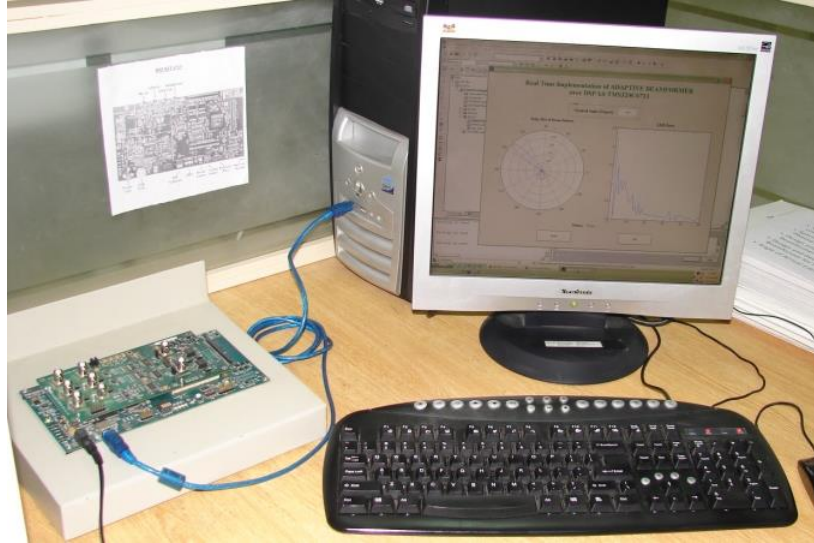

**FIGURE 8:** Hardware Setup.

Proposed hardware implementation block diagram for PAR is shown in Fig. 9. Developed system can be used in digital beamforming PAR provided ULA signals are routed to DSP kit through FPGA interfaced to high speed Analog to Digital Converter (ADC's). ADC will sample the antenna signals in reception mode and DAC's will be used to send data to antenna elements in transmission mode. ADC's, Digital to Analog Converter (DAC's) and other hardware will be interfaced to FPGA because of its parallel processing feature. FPGA will also handle data transfer and routing operation between DSP kit and ADC's/DAC's. DSP kit will perform beamforming and signal processing operations, form desired beam, extract targets from raw data and forward results to Plan Position Indicator (PPI) for display.

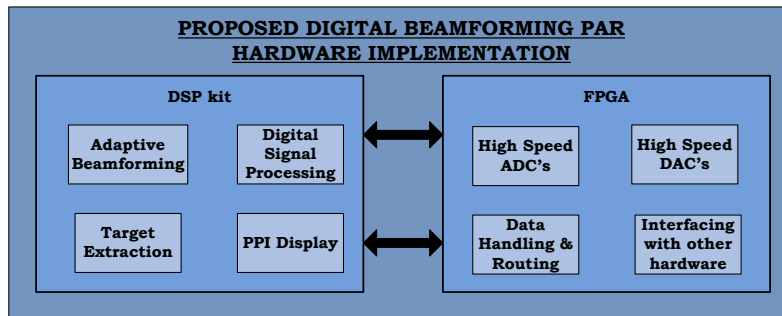

**FIGURE 9:** Proposed Hardware Implementation Block Diagram for PAR.



## 5. CONCLUSION

Digital beamforming offers advantages in terms of power consumption, flexibility, and accuracy as compared fixed beamforming techniques. In this paper, we have presented MATLAB simulation of adaptive beamformer for digital phased array radar. Real time implementation of adaptive beamformer over DSP kit was also carried out. DSP kit implementation results were also compared with MATLAB simulation results. Experimental results verify effectiveness of implementation. Complete solution for digital beamforming phased array radar is also proposed in this paper. Developed system can be used for digital beamforming after interfacing high speed ADC's to DSP kit.

## REFERENCES

1. R. Miura, T. Tanaka, I. Chiba, A. Horie and Y. Karasawa, "Beamforming Experiment with a DBF Multibeam Antenna in a Mobile Satellite Environment," IEEE Transactions on Antennas and Propagation, Vol. 45, No. 4, pp. 707–714, 1997.
2. H. Steyskal, "Digital Beamforming – An Emerging Approach," Military Communications Conference, 1988. MILCOM 88, Conference record. Vol. 2, pp. 399-403, 1988.
3. M. Vavrda "Digital beamforming in wireless communications," Institute of Radio Electronics, Faculty of Electrical Engineering and Communication, Brno University of Technology, Purkyňova, Czech Republic.
4. (2011, May.) [Online]. Available: Wikipedia, World Wide Web, [http://en.wikipedia.org/wiki/Active\\_Electronically\\_Scanned\\_Array](http://en.wikipedia.org/wiki/Active_Electronically_Scanned_Array)
5. B. D. Veen and K. M Buckley, "Beamforming: A Versatile Approach to Spatial Filtering," IEEE ASSP Magazine, pp. 2-24, April 1988.
6. A. J. Rani and A.J. Lakshmi, "Phased Array Antenna and Beamforming Subsystems in Phased Array Radar," International Journal of Engineering Science and Technology, Vol. 2, No. 5, pp. 1253-1259, 2010.
7. T. Tanaka, I. Chiba, R. Mtura and Y. Karasawa, "Digital Signal Processor for Digital Multi Beam Forming Antenna in Mobile Communication," ATR Optical and Radio Communications Research Laboratories, Japan, pp. 1507-1511, 1994.
8. D. M. Pozar, Microwave Engineering, Second Edition. John Wiley & Sons, New York, 1998.
9. S. Ejaz and M. A. Shafiq, "Comparison of Spectral and Subspace Algorithms for FM Source Estimation," Progress In Electromagnetics Research C, Vol. 14, pp. 11-21, 2010.
10. T. Haynes, Digital Beamforming Primer, November 2001.
11. Vecima, Beamforming in Software Defined Radio, Spectrum Signal Processing Webinar, January 2011.
12. (2011, May.) [Online]. World Wide Web, <http://www.radartutorial.eu/06.antennas/an51.en.html>
13. V. Vakilan, "Digital Beamforming Implementation of Switch-Beam Smart Antenna System by using Integrated Digital Signal Processor and Field-Programmable Gate Array," MS Thesis, Faculty of Electrical Engineering, Universiti Teknologi Malaysia, May 2008.

14. A. D. Poularikas and Z. M. Ramadan, Adaptive Filtering Primer with Matlab, Taylor and Francis Group, 2006
15. N. kehtarnavaz, Real-time digital signal processing based on the TMS320C6000, ELSEVIER, 2005.
16. R. Chassaing, Digital Signal processing and applications with the C6713 and C6416 DSK, A John Wiley and Sons, Inc., Publications, 2005.
17. (2011, May.) [Online]. Available: Texas instruments DSP developer's village. World Wide Web, [www.dspvillage.ti.com](http://www.dspvillage.ti.com)